



MN-86KS MN-86K

产品安装说明书

《PRODUCT INSTALLATION INSTRUCTIONS》





莽牛模型交流群

扫一扫二维码，入群聊。

MN MODEL COMMUNICATION GROUP QQ

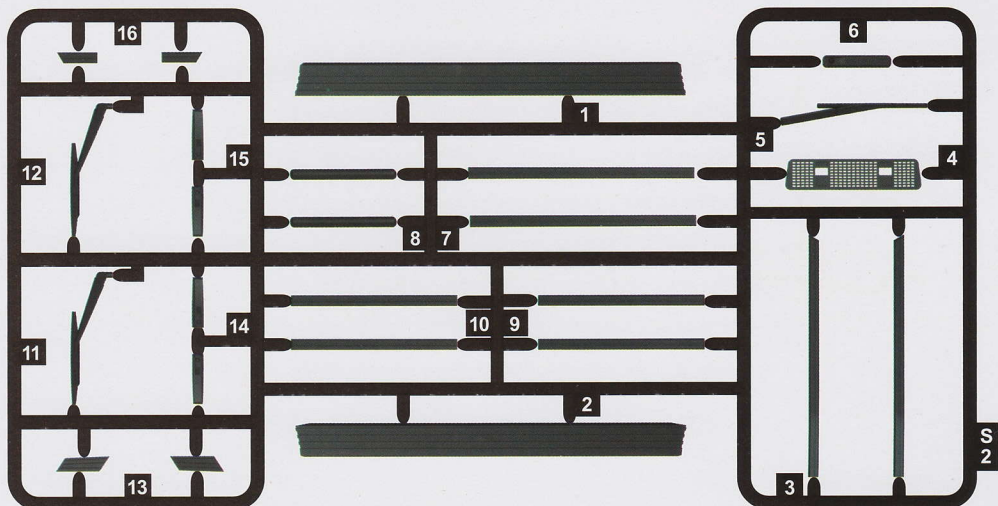
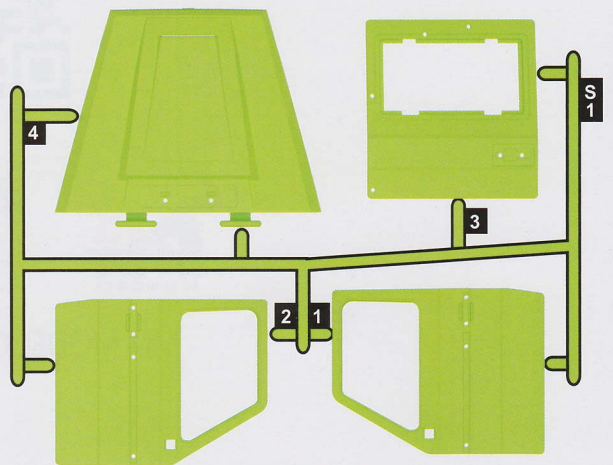
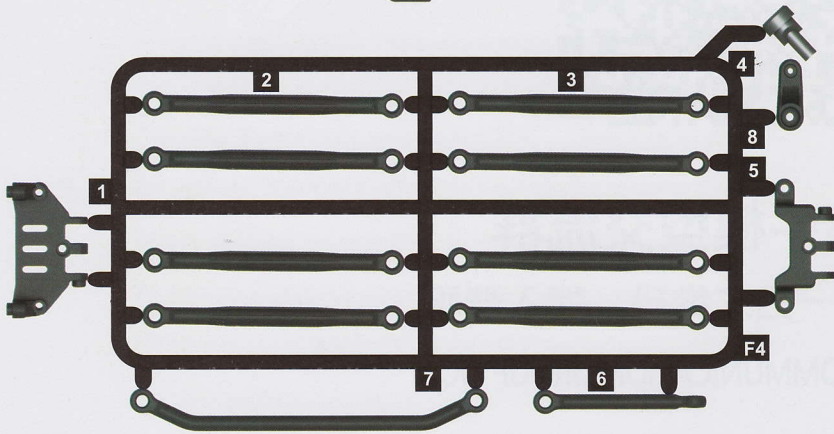
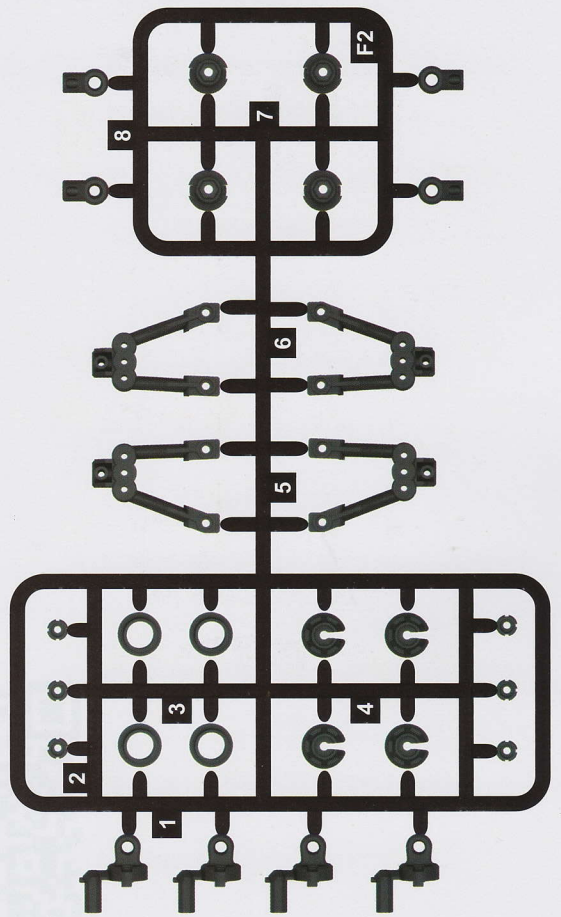
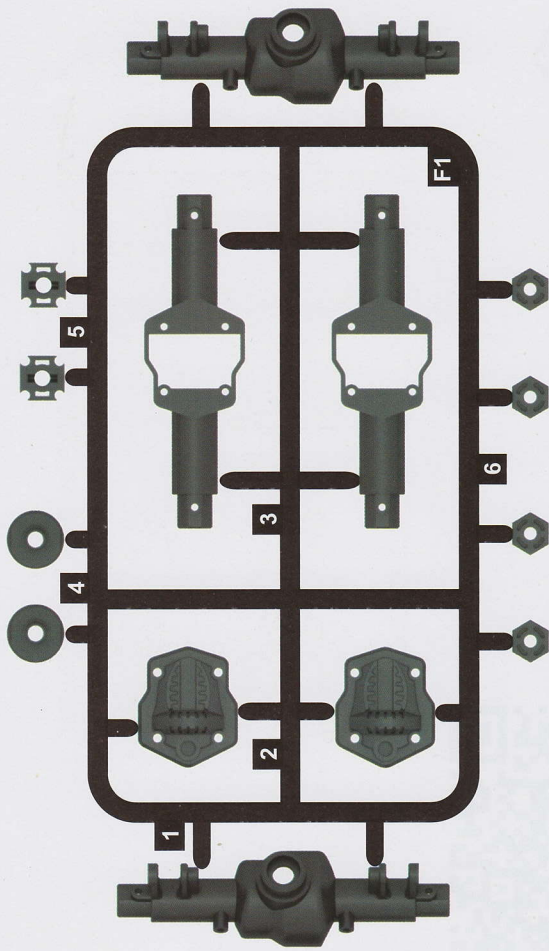

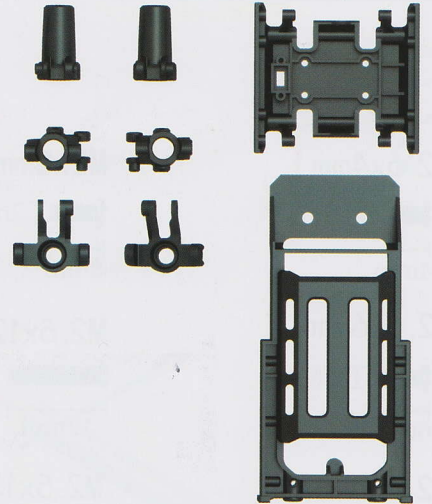
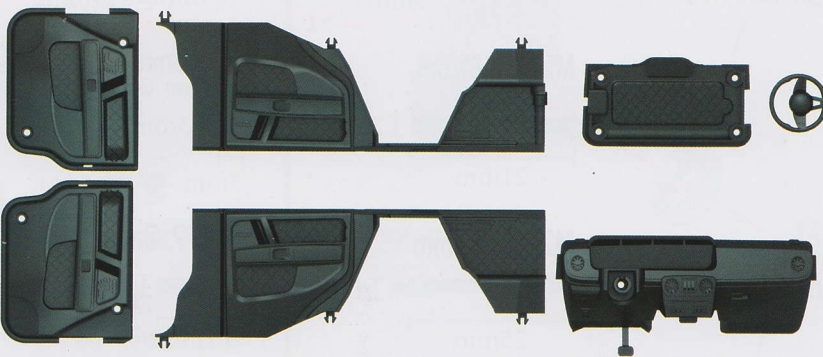
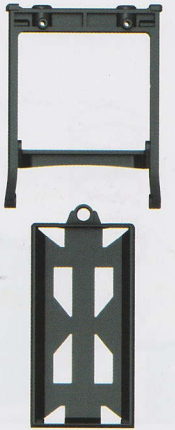
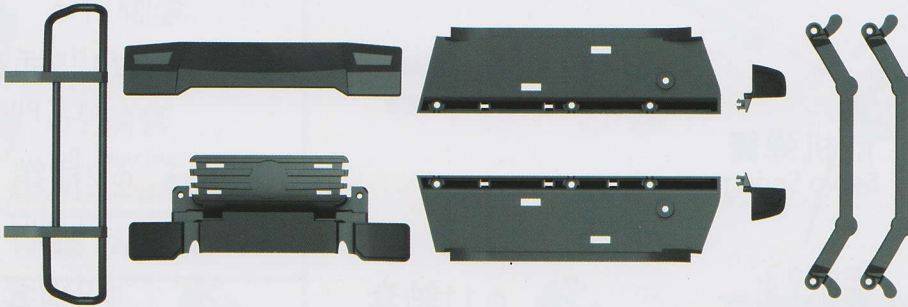
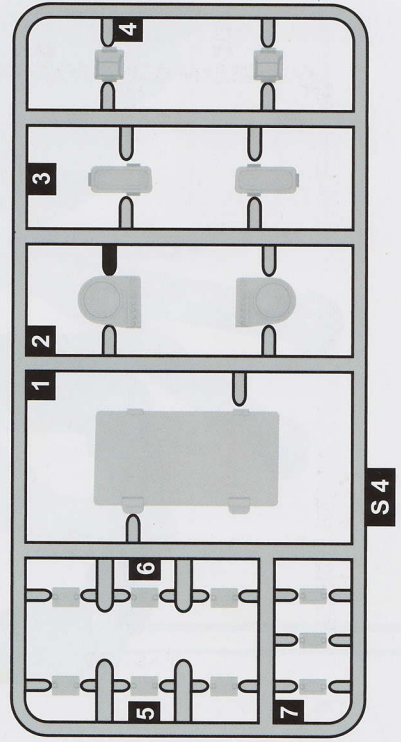
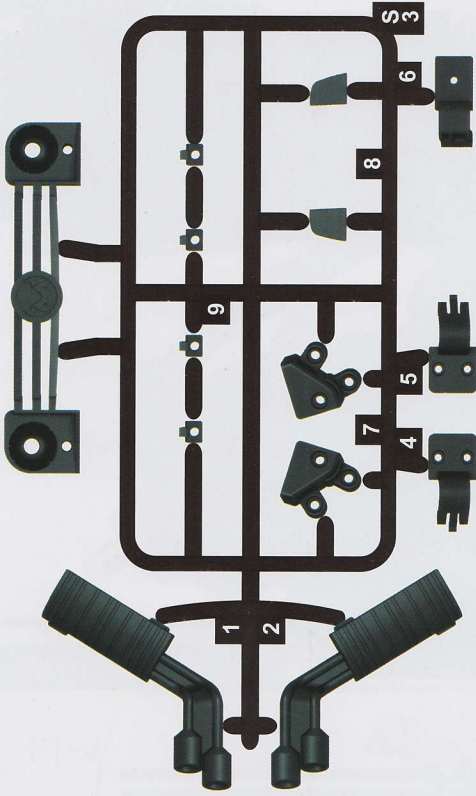

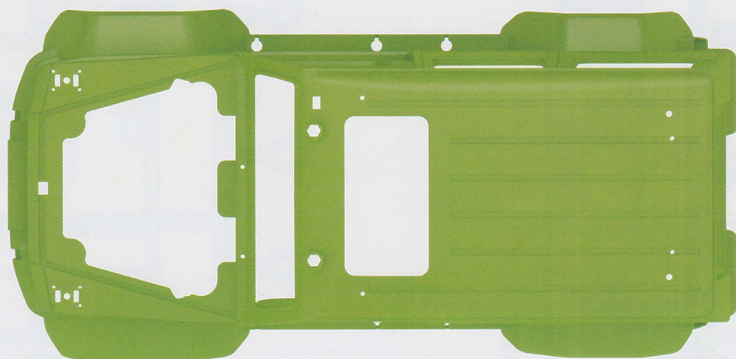
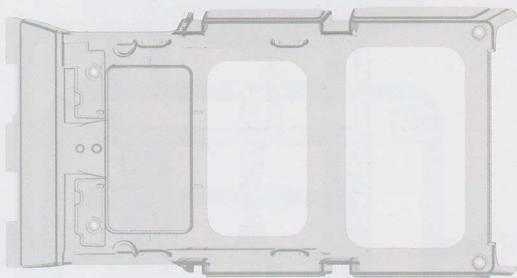

大梁
Chassis Rail



舵机弹簧
Servo Spring



φ 1.5 插销
φ1.5 PIN



φ 2 插销
φ2 pin



φ 11 轴套
φ11 Bearing



φ 9 轴套
φ9 Bearing



11mm



3mm



9mm



3mm

2.6x4mm

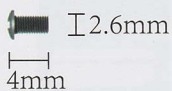

M2x8mm

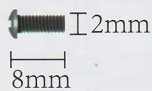

M2.5x21mm

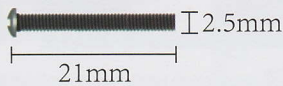

M3x3mm 机米螺丝
M3X3mm Grub screw

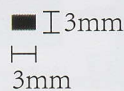

2.6x6mm

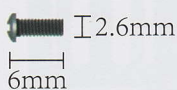

M2.5x12mm

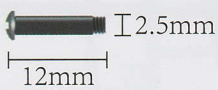

M2.5x25mm

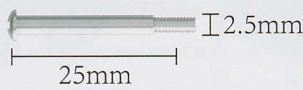

M3x9.2mm

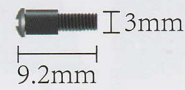

2.6x6+6mm

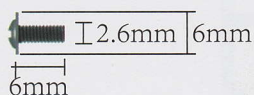

M2.5x13mm

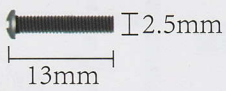

M4 防松螺母
M4 Locknut



plan A

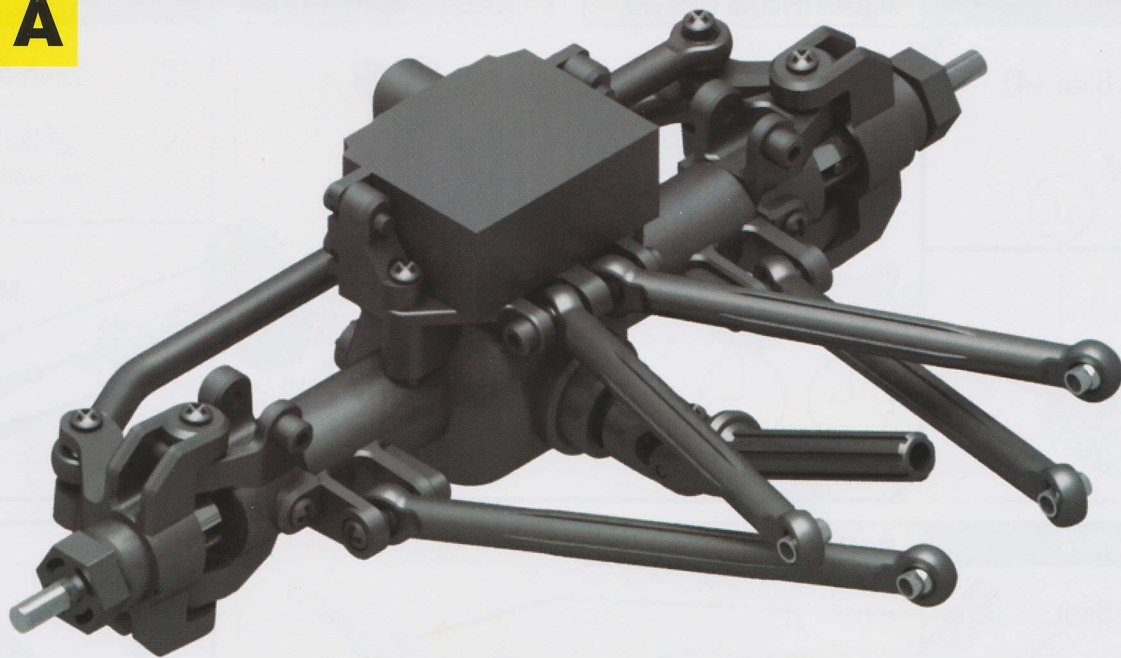

prepare



Assemble steps

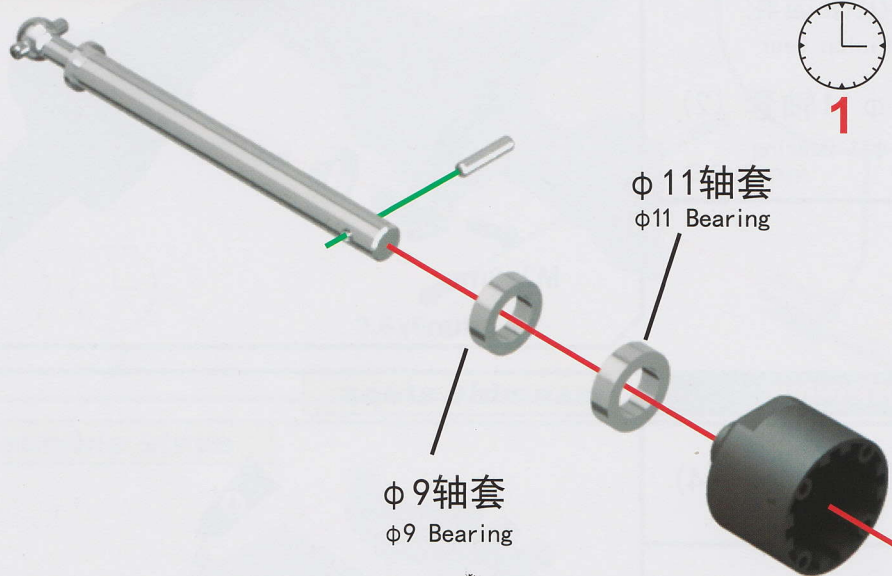

prepare



Assemble steps

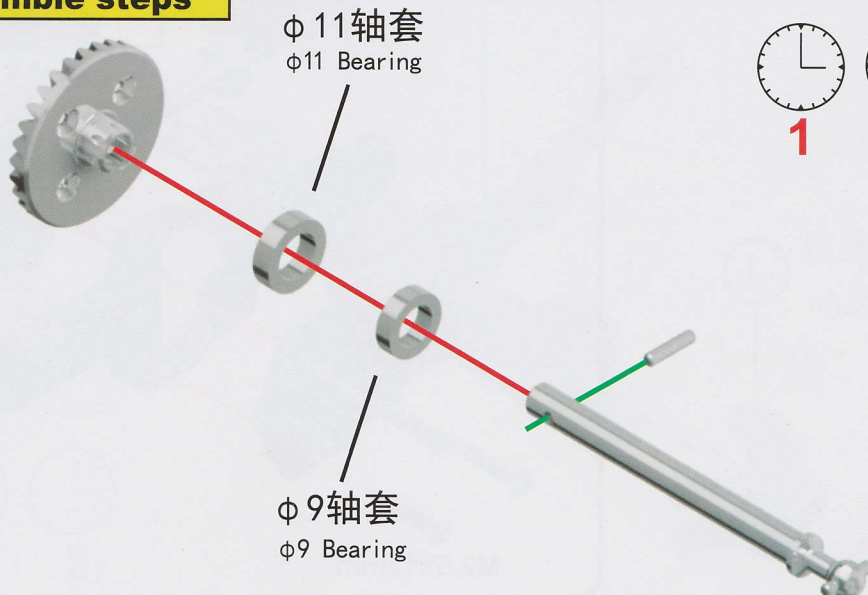

prepare

M2x8mm (4)

F1-5

Assemble steps

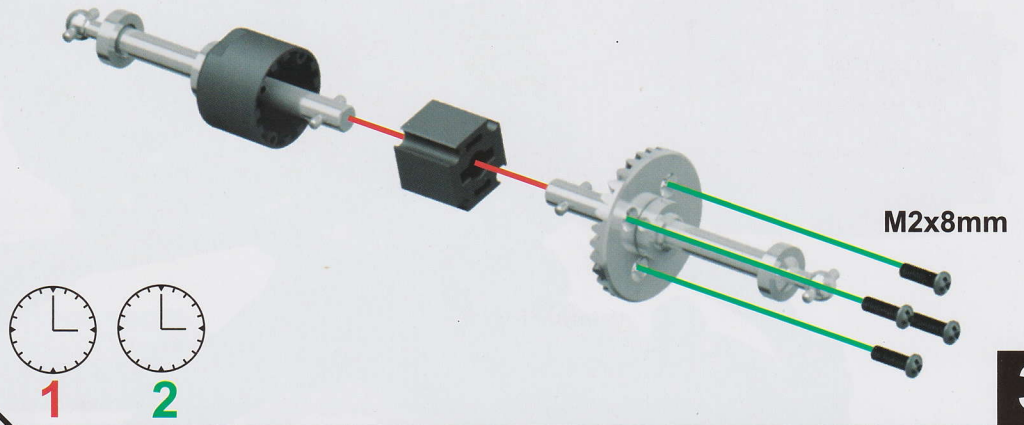

prepare

M2x8mm

M2.5x12mm

小锥齿轮
Pinion Gear

φ 11轴套 (2)
φ11 Bearing

Assemble steps

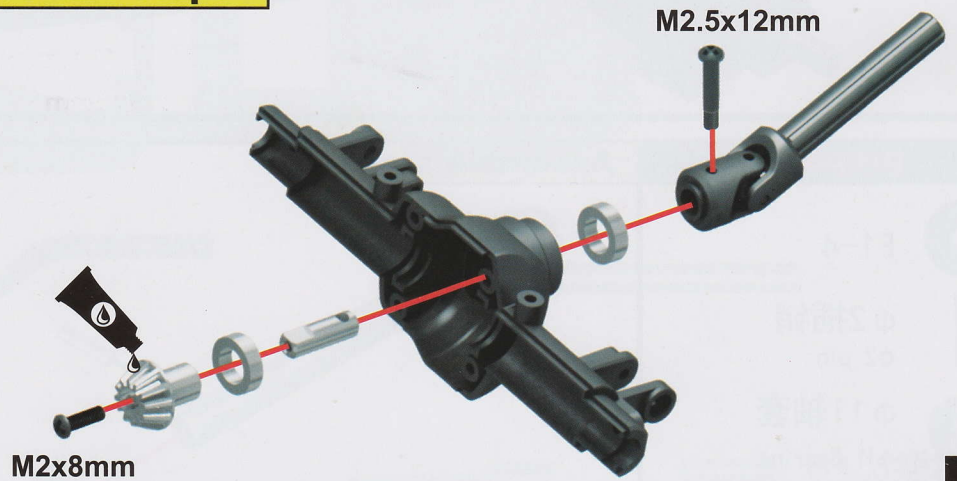

prepare

M2.5x13mm (4)

Assemble steps

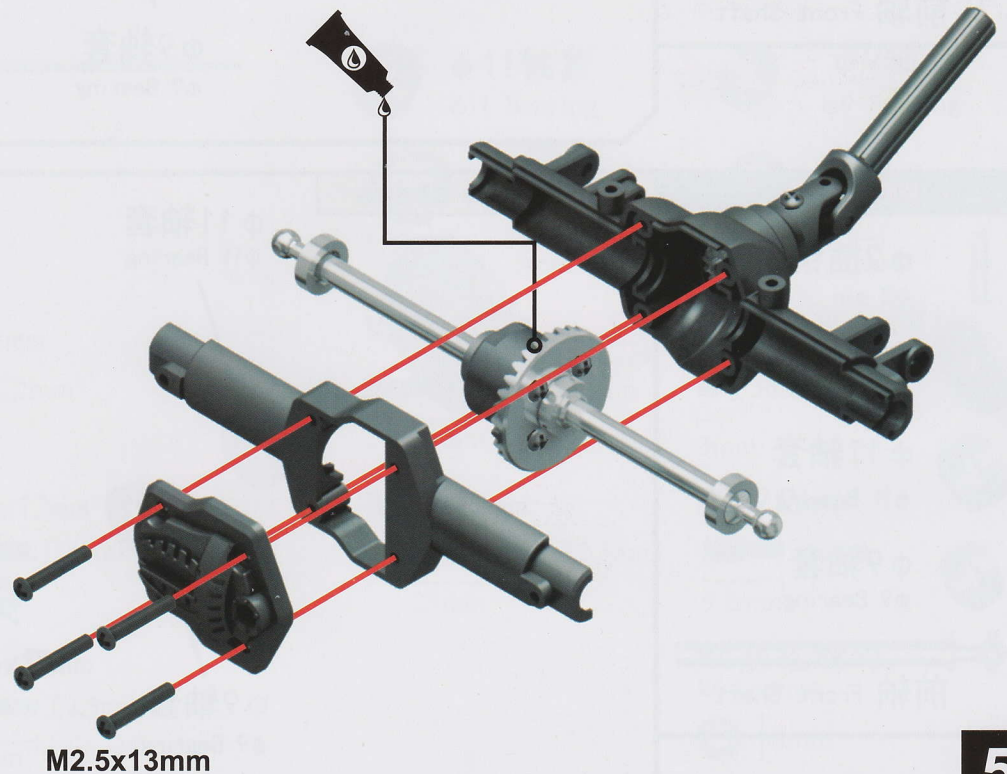

prepare

-  2.6x6mm (2)
-  φ9轴套 (2)
φ9 Bearing

Assemble steps

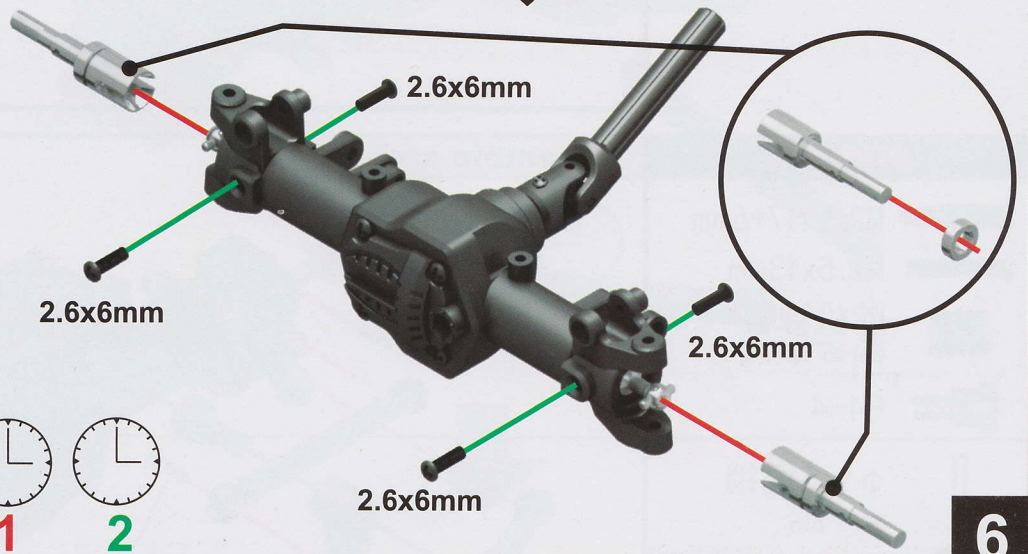

6

prepare

-  φ9轴套 (2)
φ9 Bearing

Assemble steps

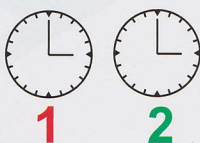
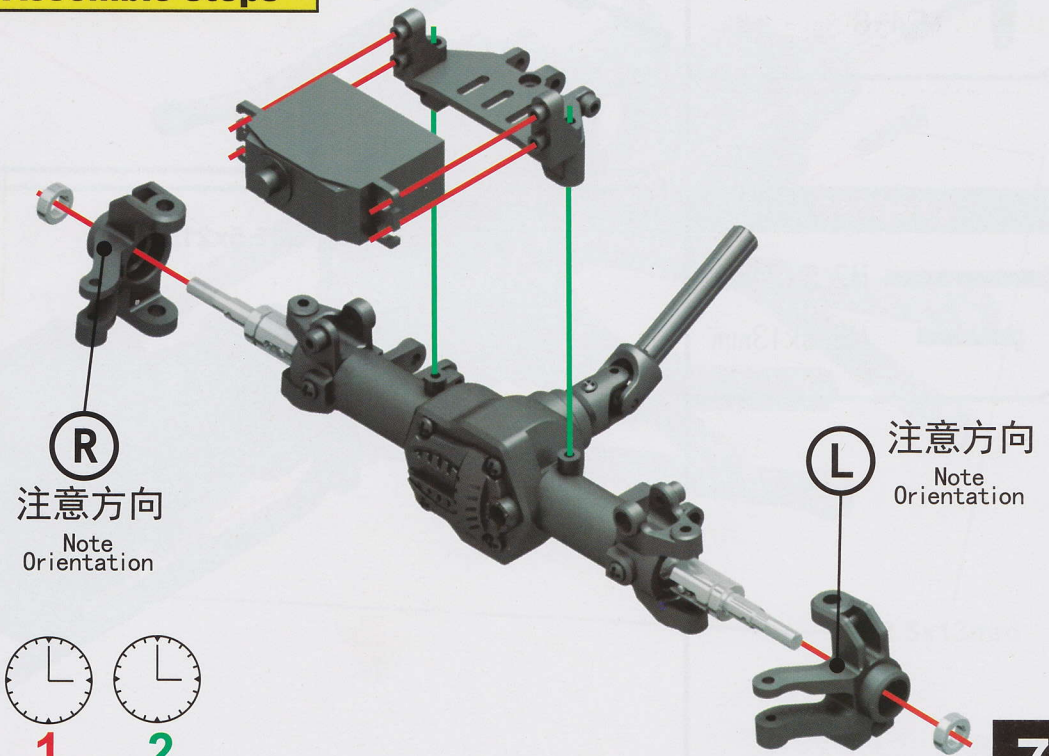

7



prepare

- M2.5x13mm (2)
- M3x10mm (4)
- 2.6x6+6mm (4)

Assemble steps

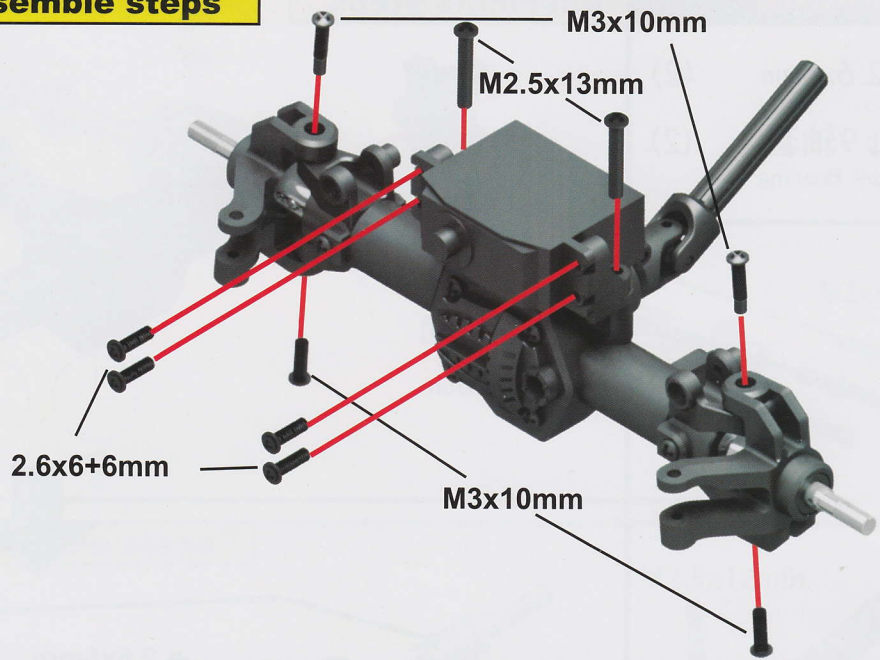

8

prepare

- M2.5x17+6mm
- M2.5x13mm
- 舵机弹簧
Servo Spring
- F4-4
- φ 1.5插销
φ1.5 pin
- F1-6 (2)
- F4-8

Assemble steps

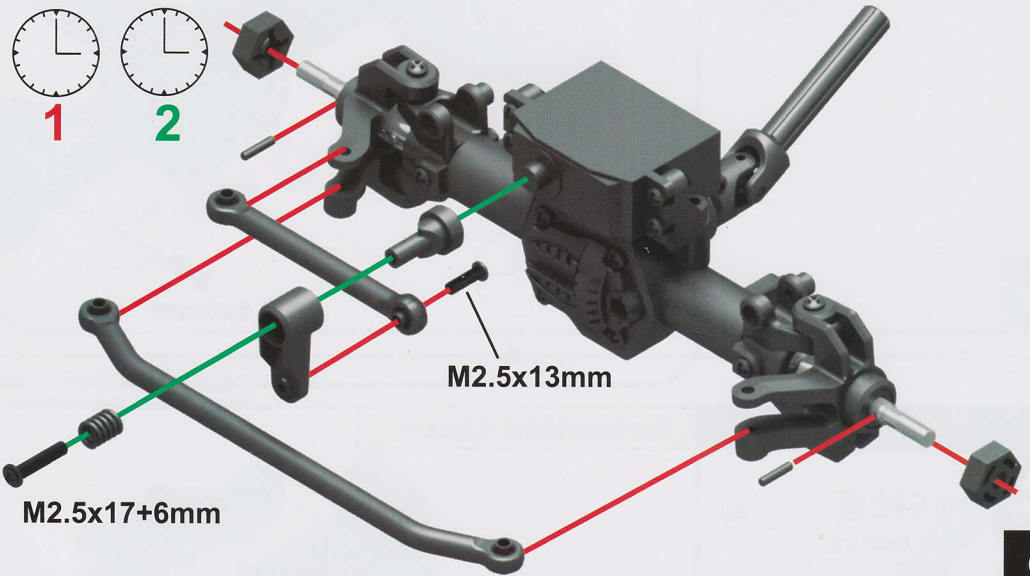

9

prepare

- M2.5x21mm
- M2.5x13mm

Assemble steps

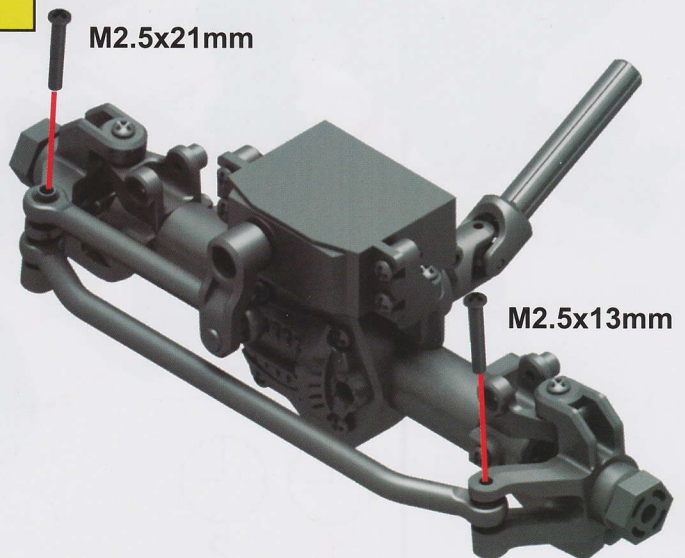

10

prepare

M2.5x13mm (2)

M2.5x25mm

Assemble steps

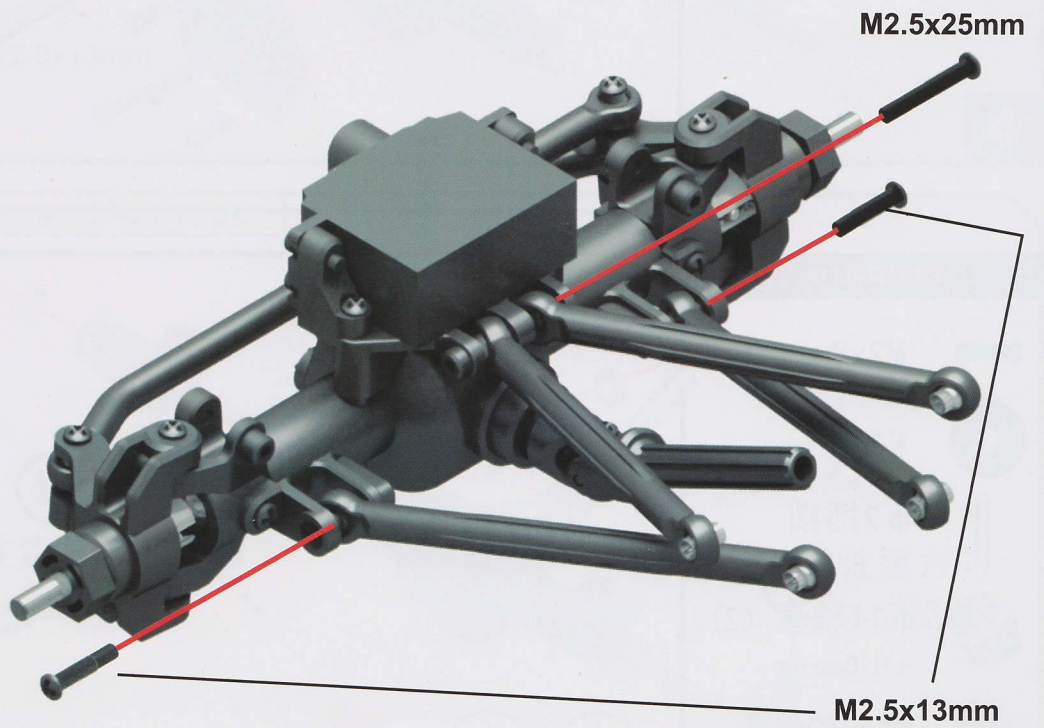
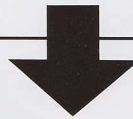
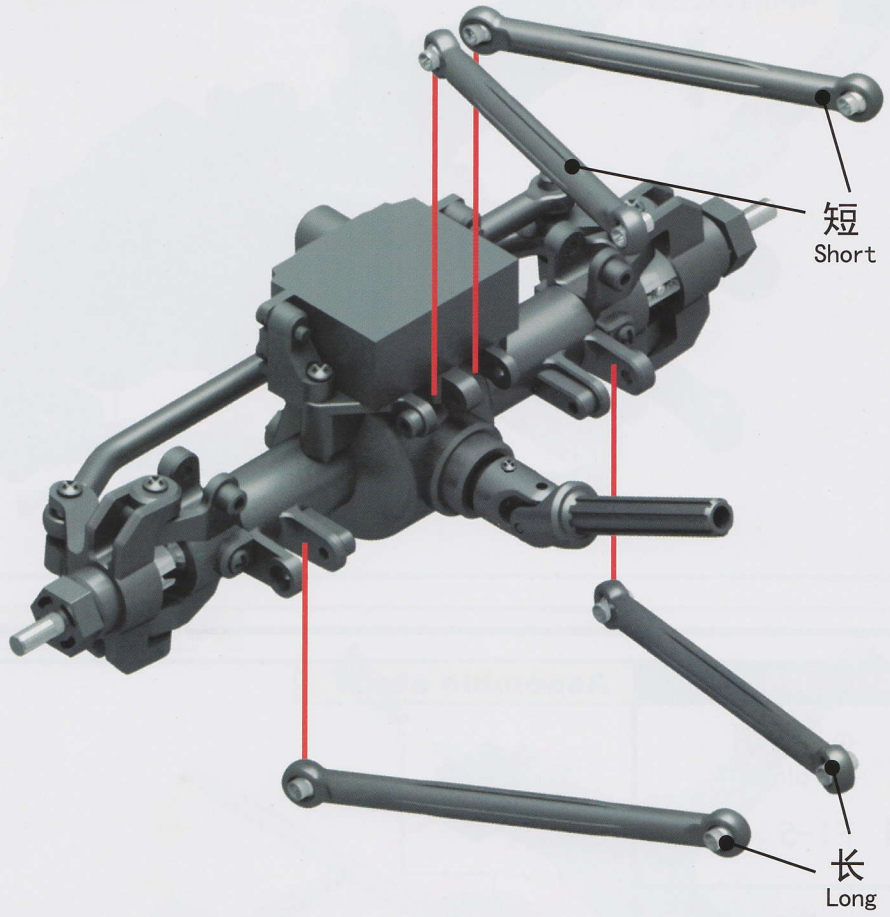

plan B

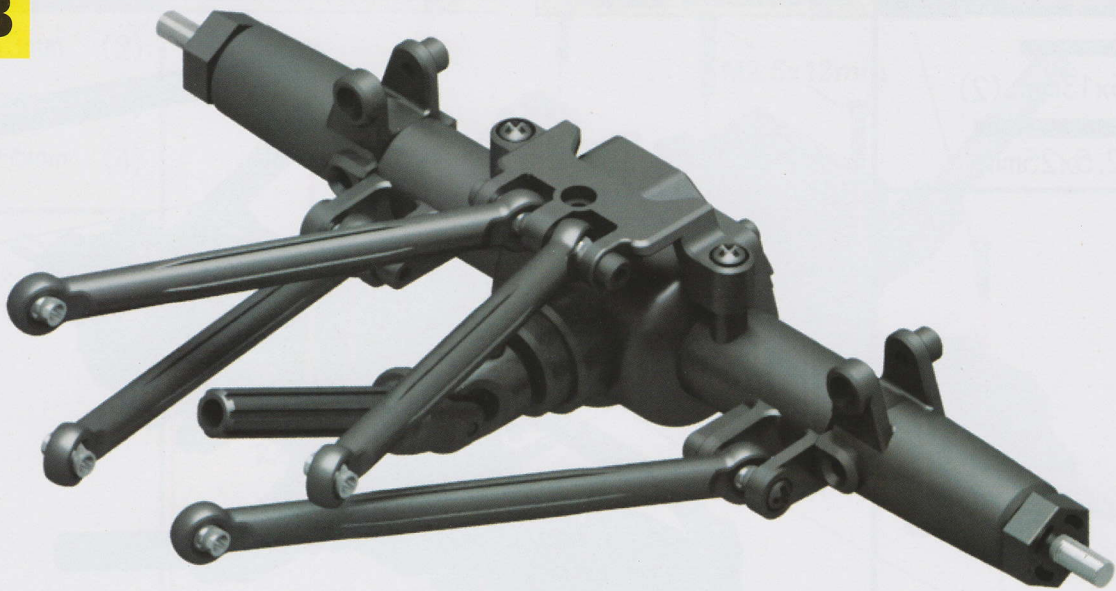

prepare



φ 2插销
φ2 pin



F1-5

Assemble steps

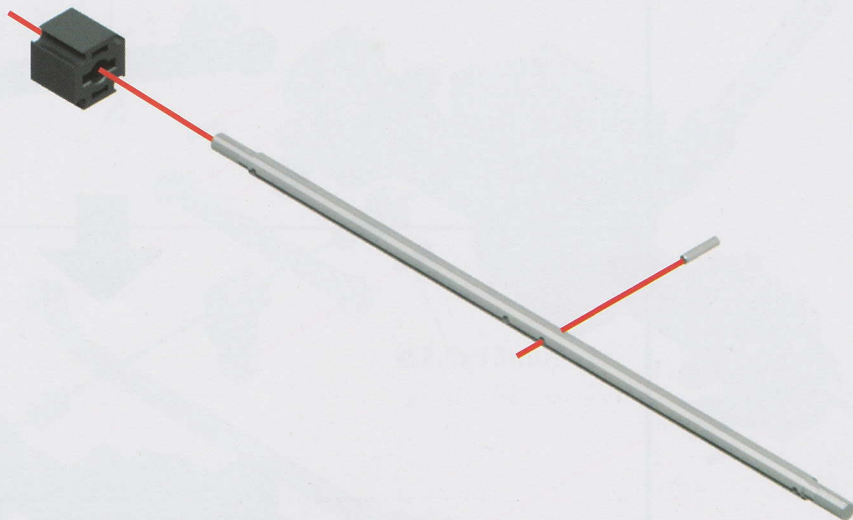

1

prepare



M2x8mm (4)



F1-4



φ 2插销
φ2 pin



φ 11轴套 (2)
φ11 Bearing



锥齿轮
Ring Gear

Assemble steps

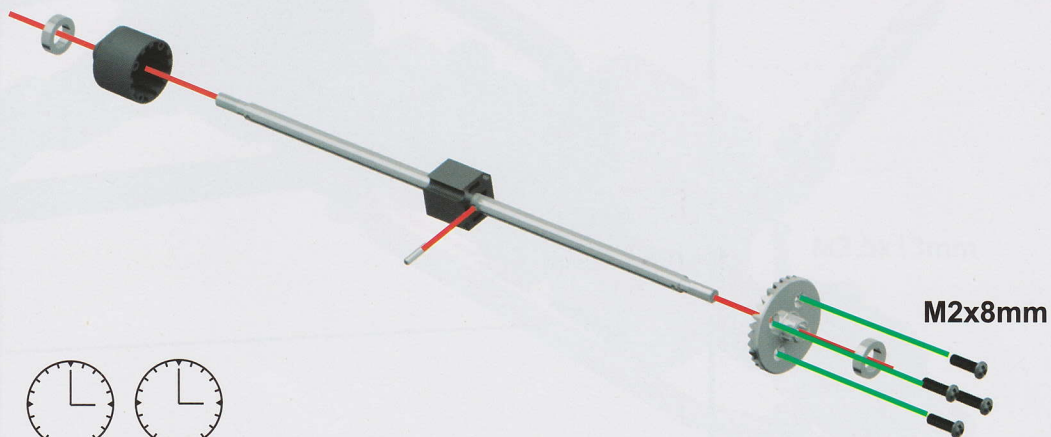

M2x8mm

1

2

2

prepare

- M2x8mm
- M2.5x12mm
- 小锥齿轮
Pinion Gear
- φ 11轴套 (2)
φ11 Bearing

Assemble steps

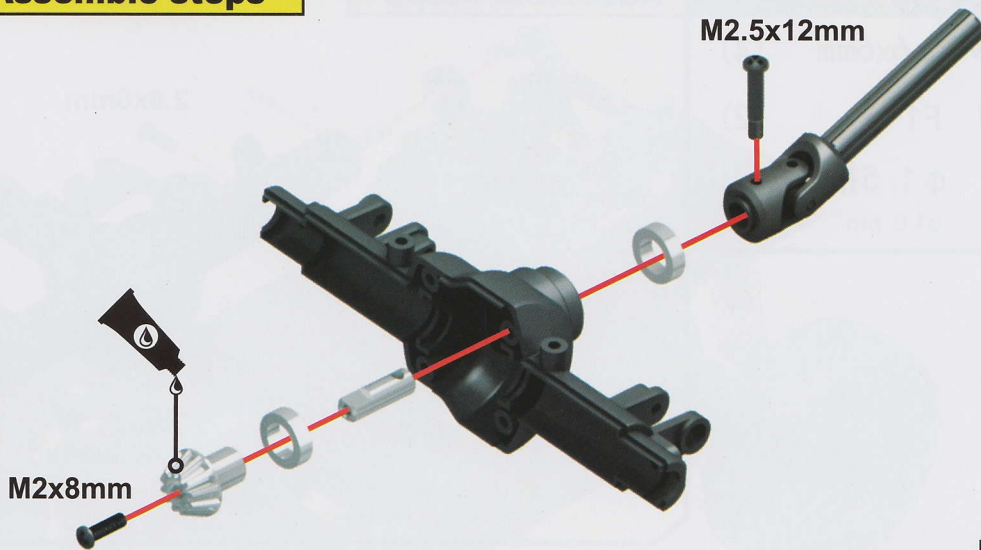

3

prepare

- M2.5x13mm (4)

Assemble steps

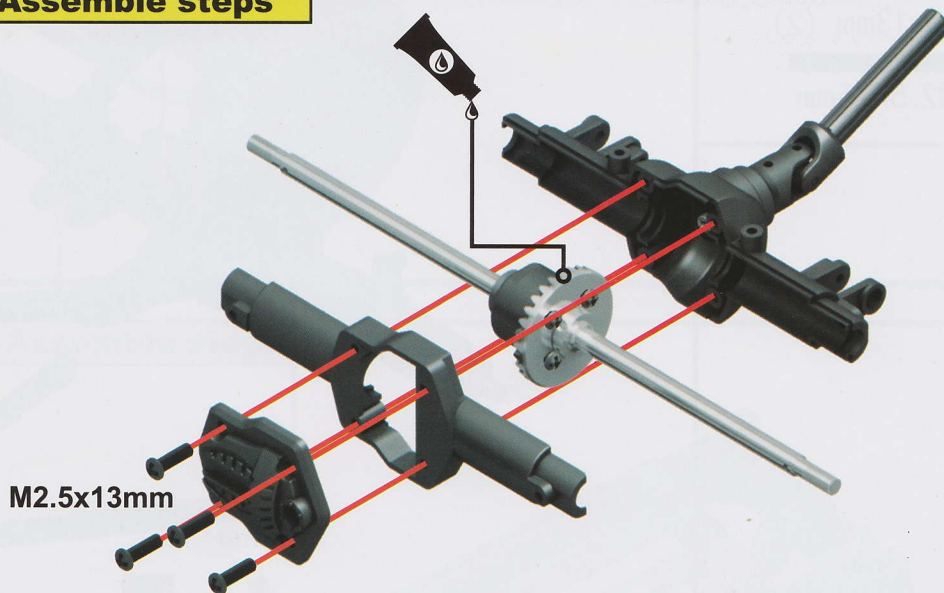

4

prepare

- M2.5x13mm (2)
- φ 9轴套 (2)
φ9 Bearing

Assemble steps

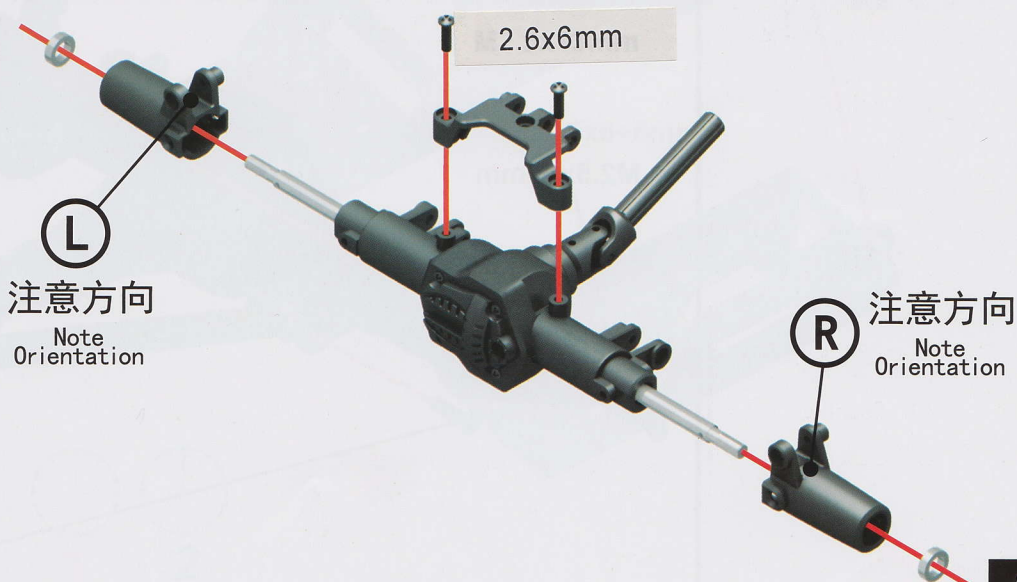

5

prepare

-  2.6x6mm (4)
-  F1-6 (2)
-  $\phi 1.5$ 插销 (2)

Assemble steps

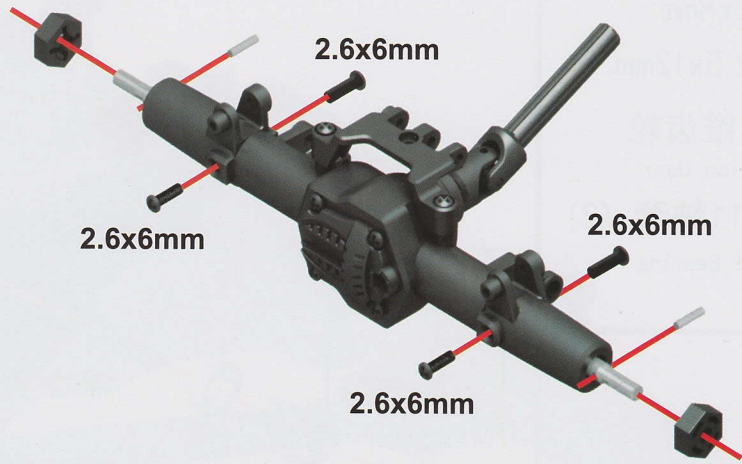

6

prepare

-  M2.5x13mm (2)
-  M2.5x25mm

Assemble steps

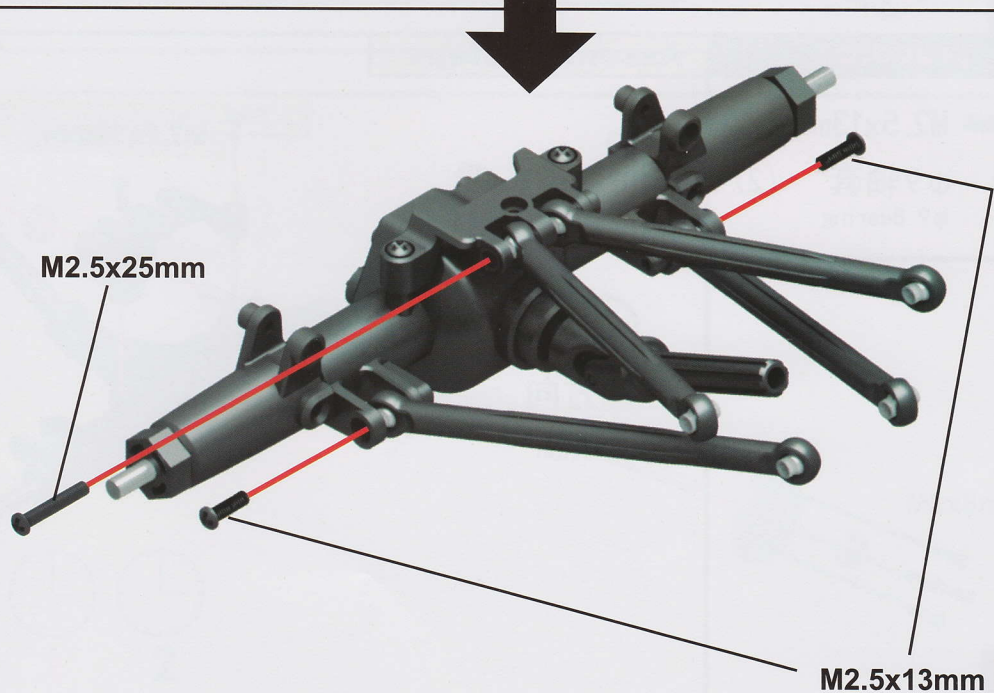
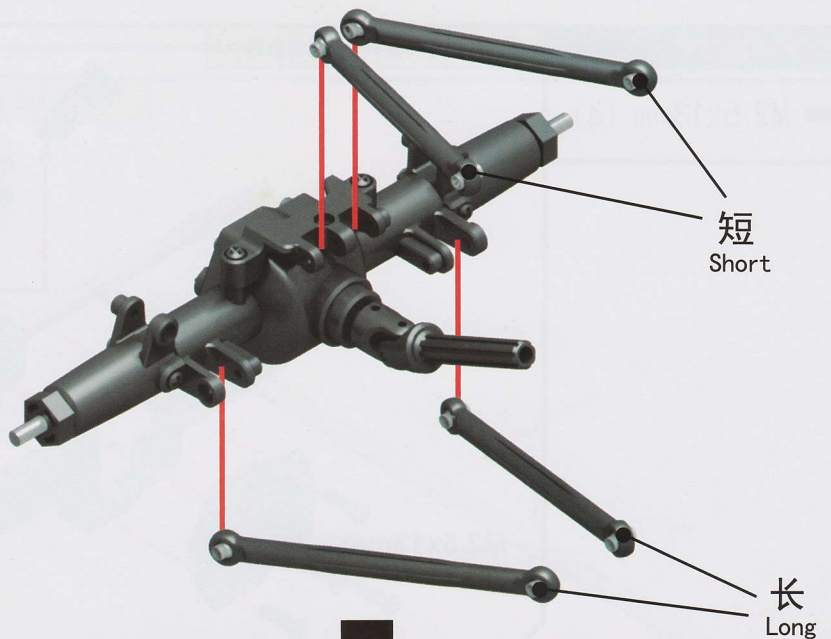

7

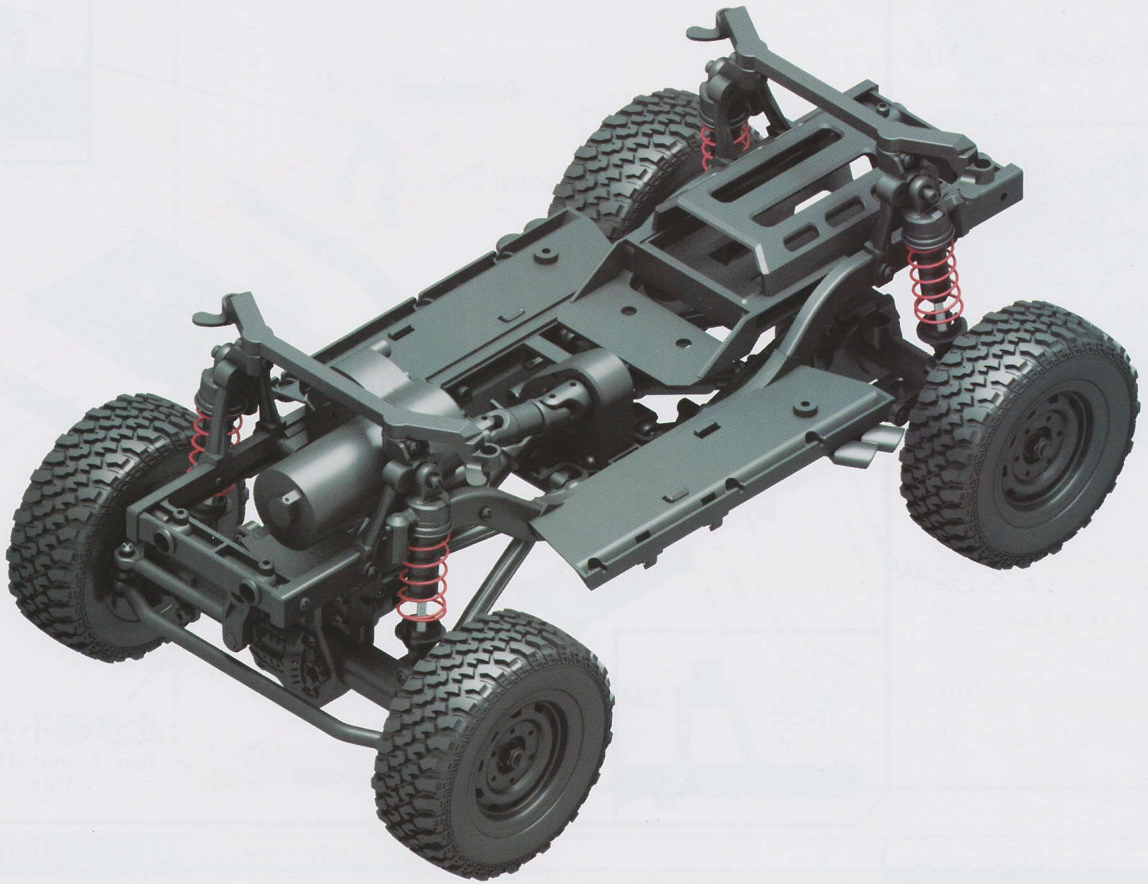

prepare

 2.6x6+6mm (2)
 带帽螺丝
 Flathead Cap Screw



 插销
 R pin

Assemble steps

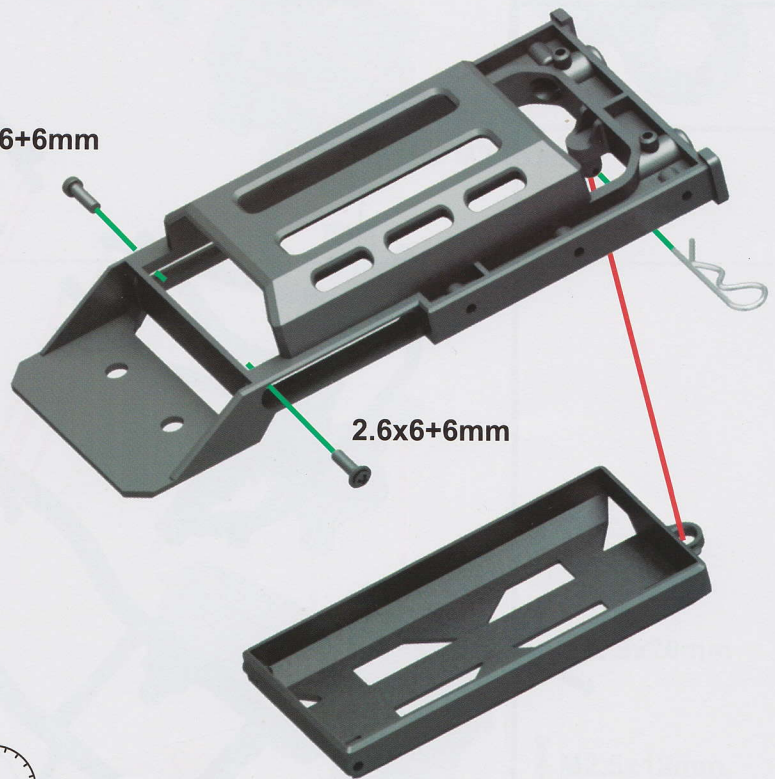
2.6x6+6mm

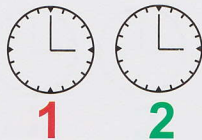

2.6x6+6mm



prepare

2.6x6mm (10)

Assemble steps

注意方向
Note
Orientation

(R)

2.6x8mm

2.6x8mm

2.6x8mm

2.6x8mm

此步骤不打螺丝
Don't install screw
in this step

2

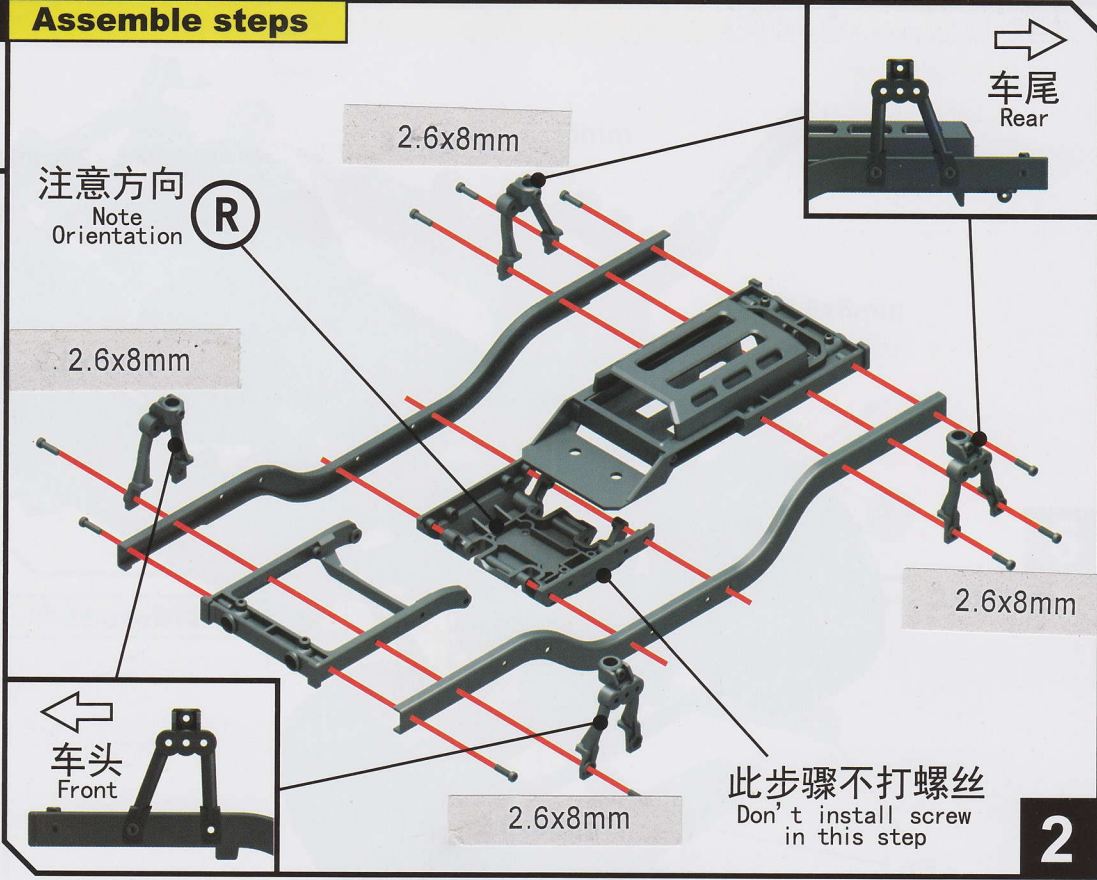
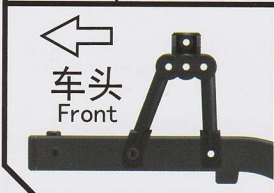
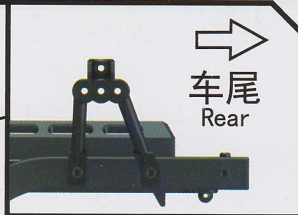

prepare

Assemble steps

(A)

(B)

(A)

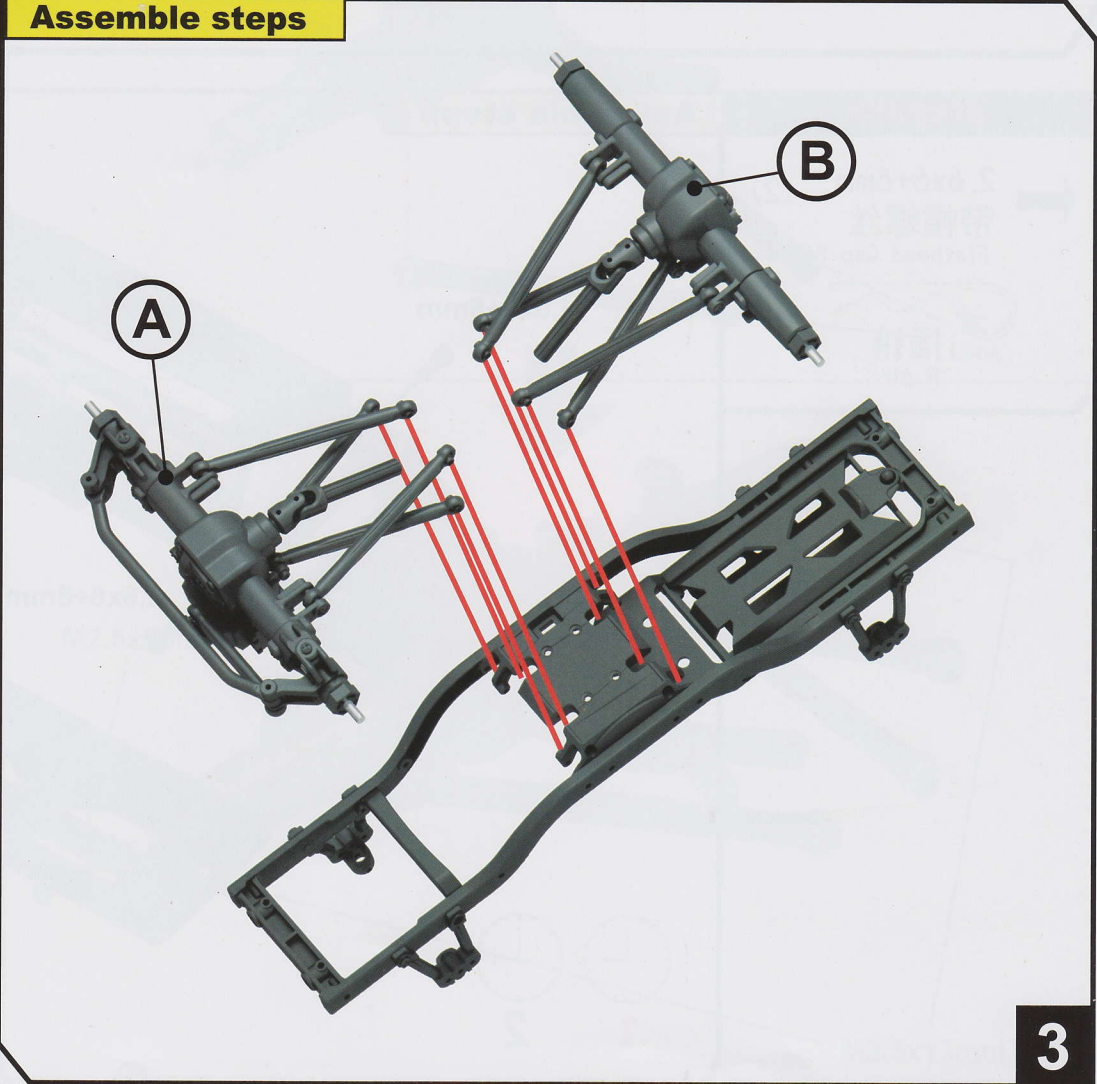

(B)



3



prepare

-  M2.5x21mm (4)
-  M2.5x13mm (4)

Assemble steps

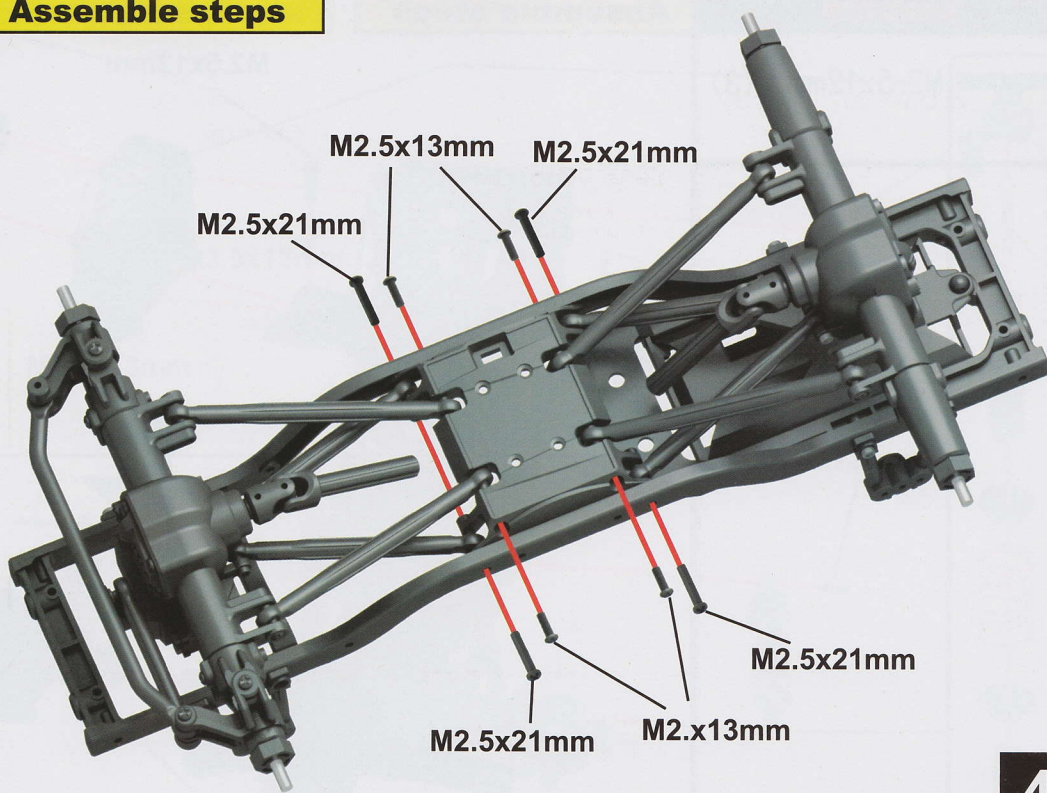

4

prepare

-  M2.5x6mm (2)
-  M3x3mm
机米螺丝
Grub Screw
-  M2.5x12mm
-  M2.5x20mm (2)

Assemble steps

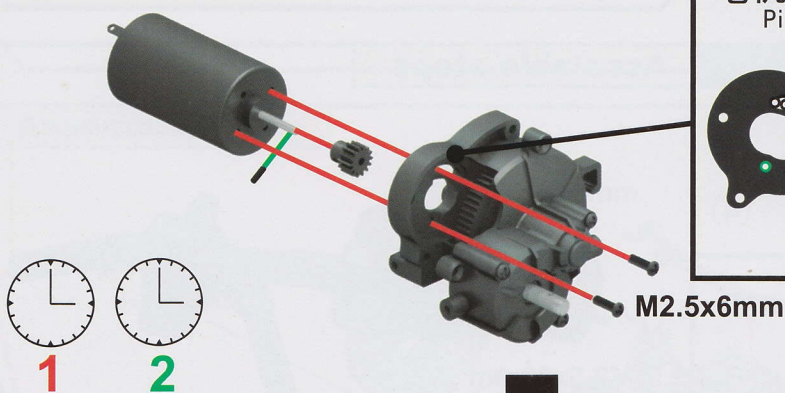

电机齿轮齿数

Pinion Gear

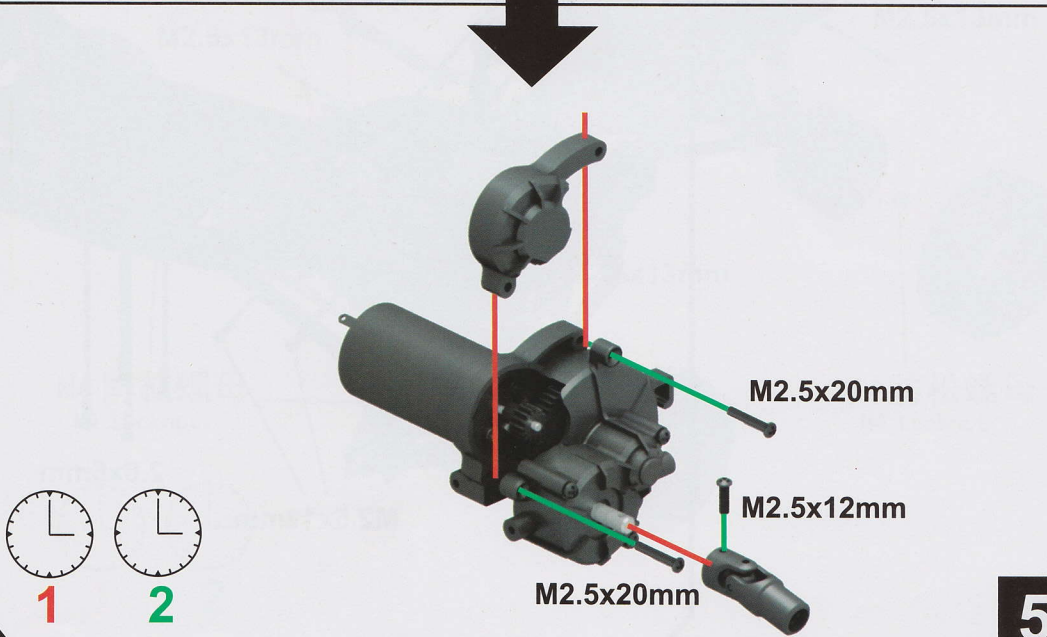
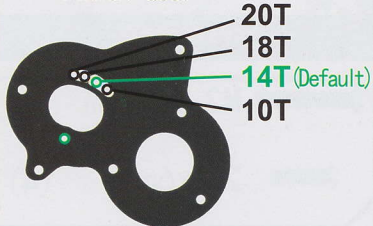

5

GEAR RATIO

Pinion Gear	Spur Gear
	70T
10	69.5
11	63.2
12	57.9
13	53.5
14 Default	49.6
18	38.6
19	36.6
20	34.7

prepare

Assemble steps

M2.5x12mm (3)

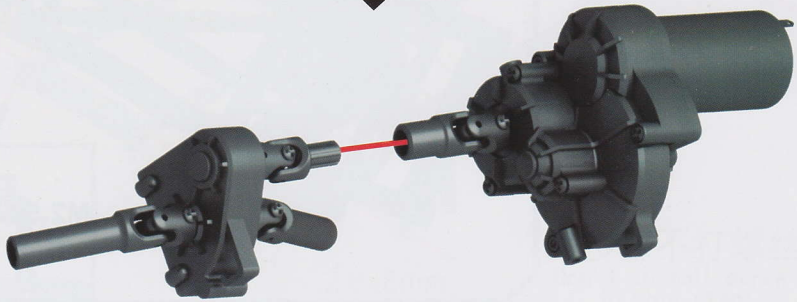
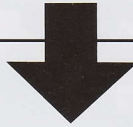
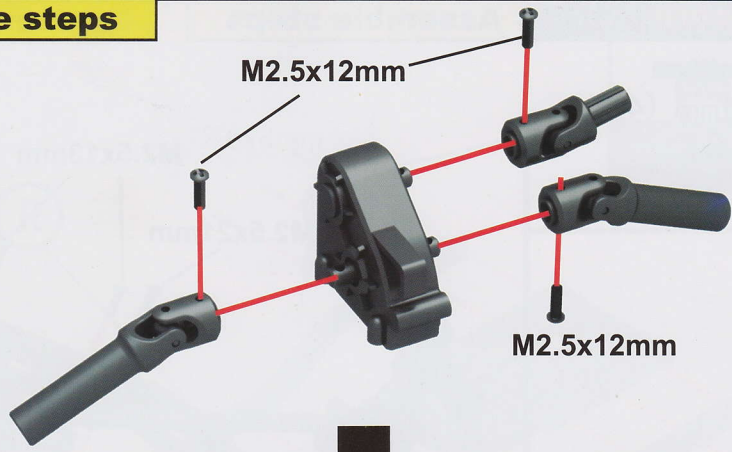

6

prepare

Assemble steps

M2.5x13mm (4)

2.6x6mm (4)

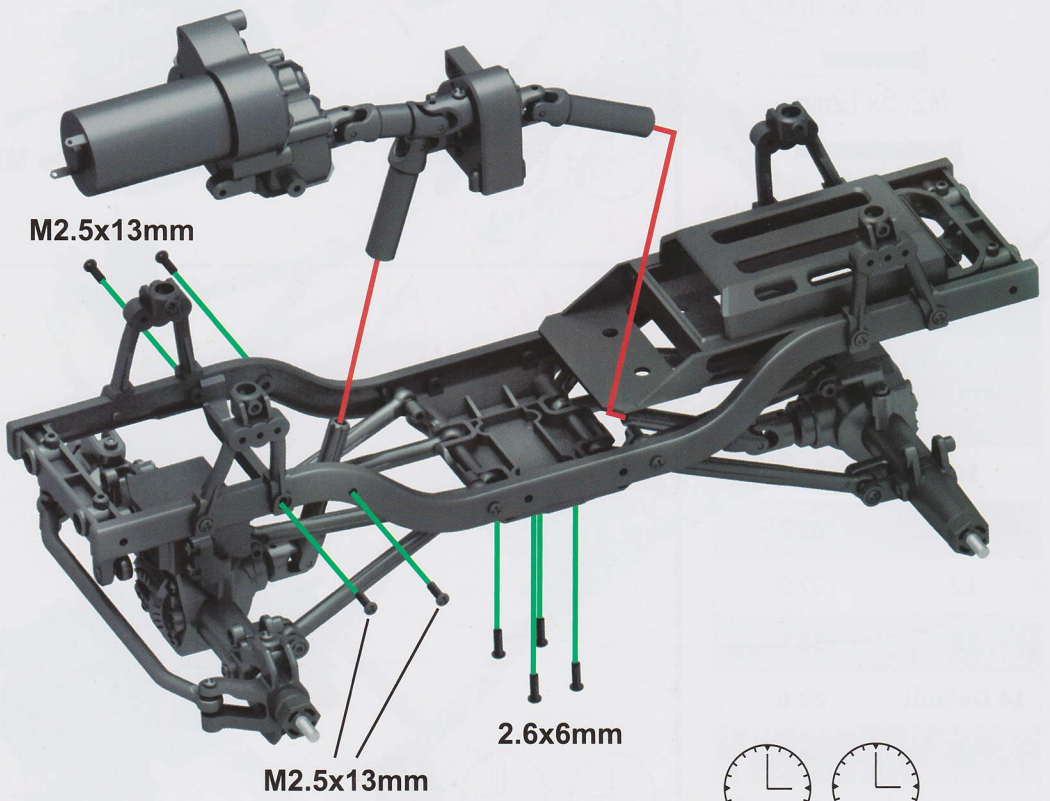



1

2

7

prepare

-  M2.5x13mm (8)
-  M2.5x25mm (4)

Assemble steps

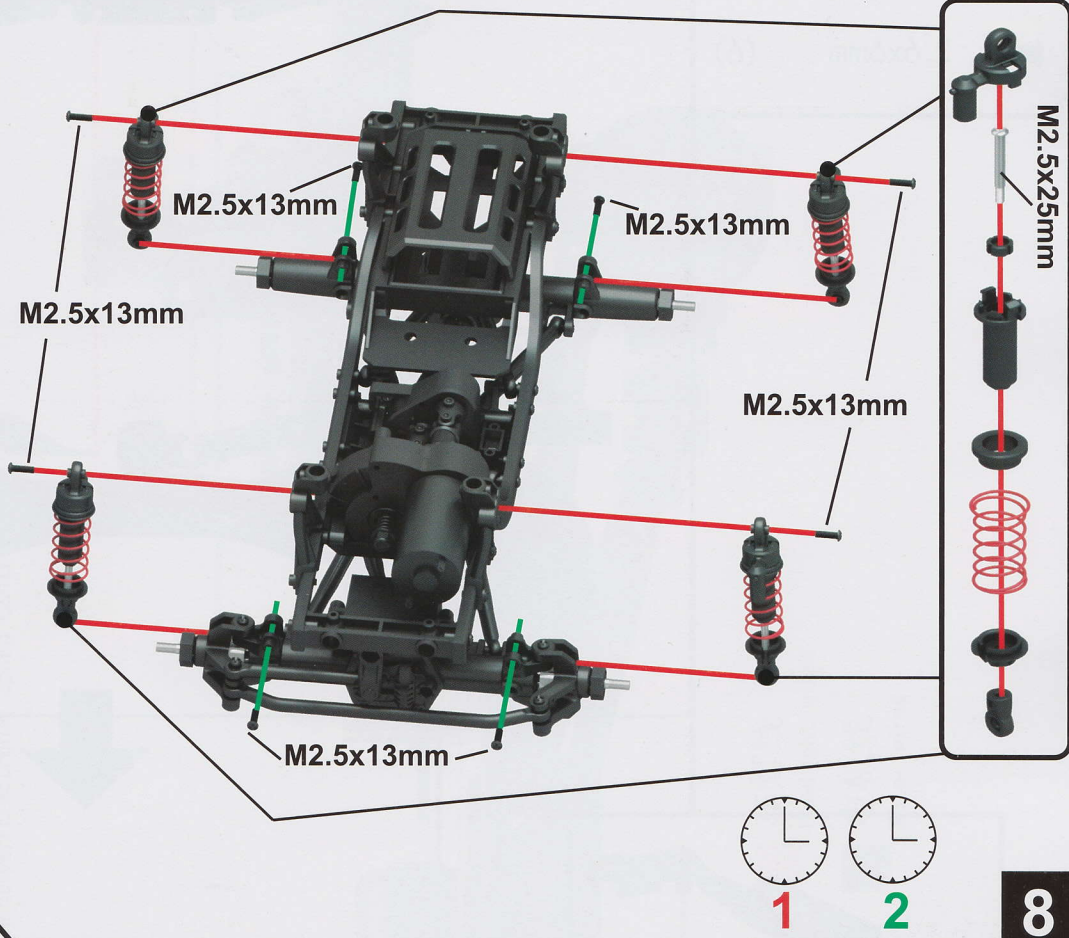

prepare

-  M2.5x13mm (4)
-  M4 防松螺母 (4)
M4 Locknut

Assemble steps

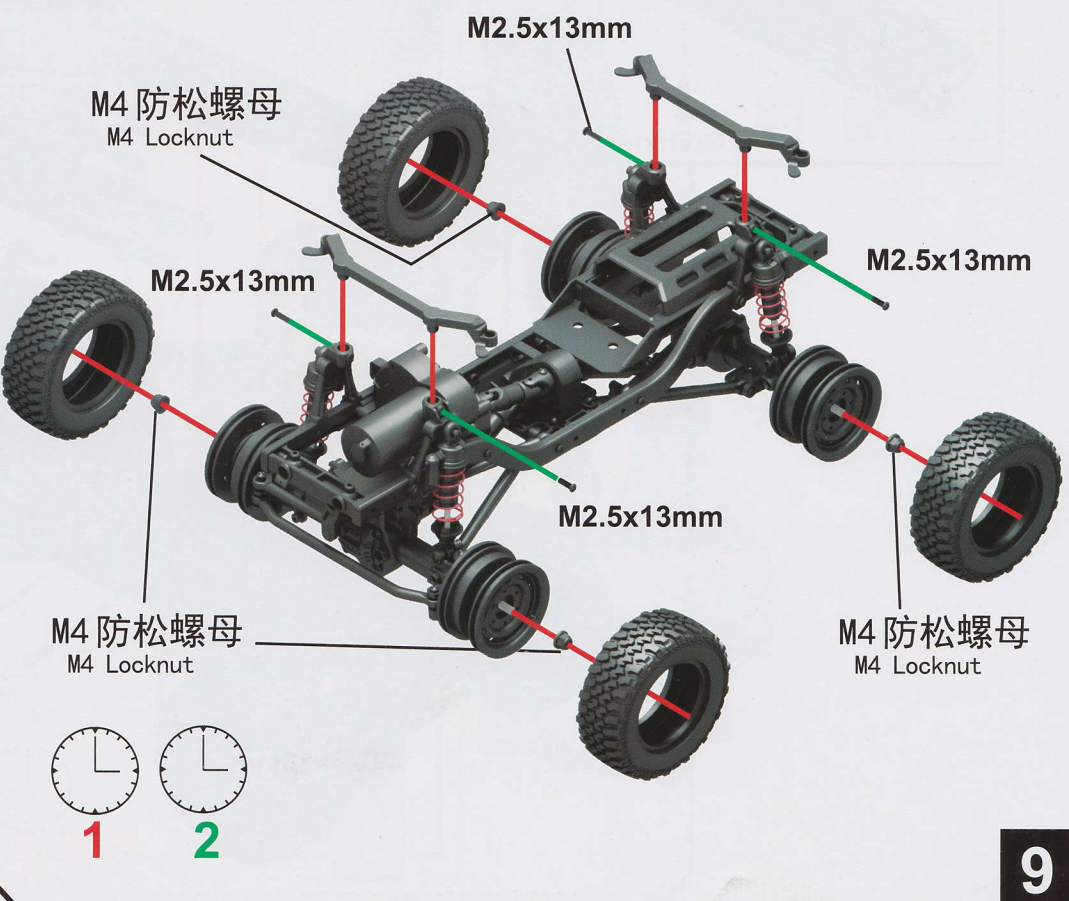

prepare

Assemble steps

 2.6x6mm (6)

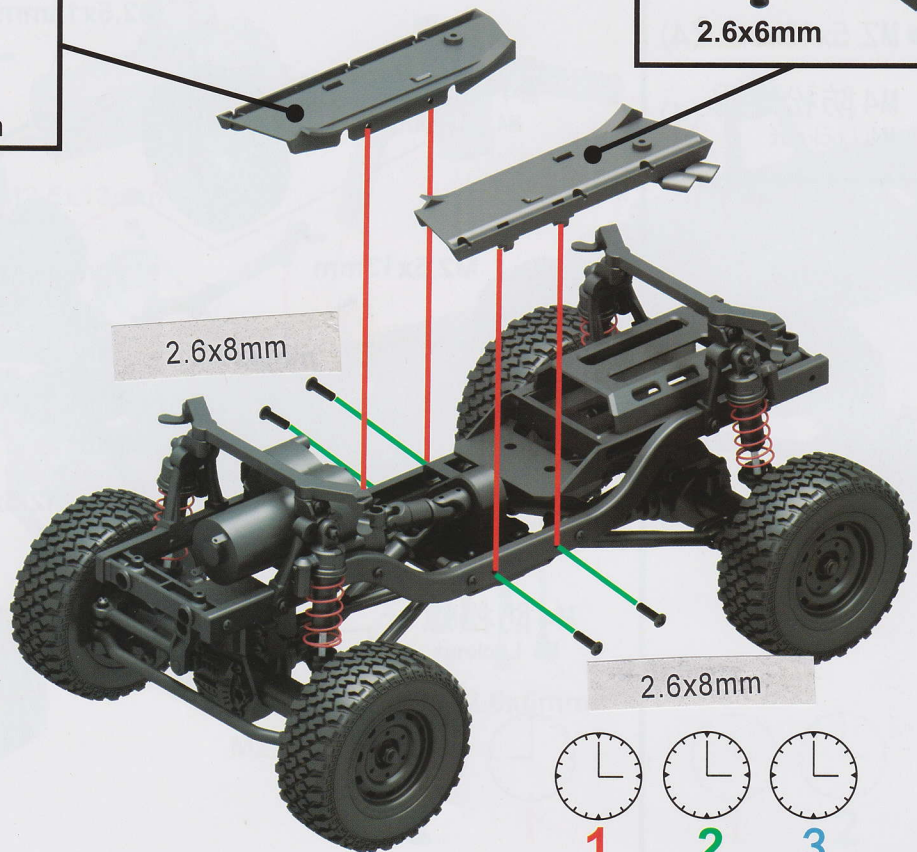
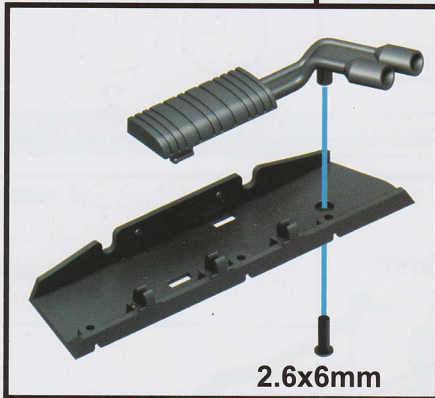
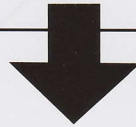
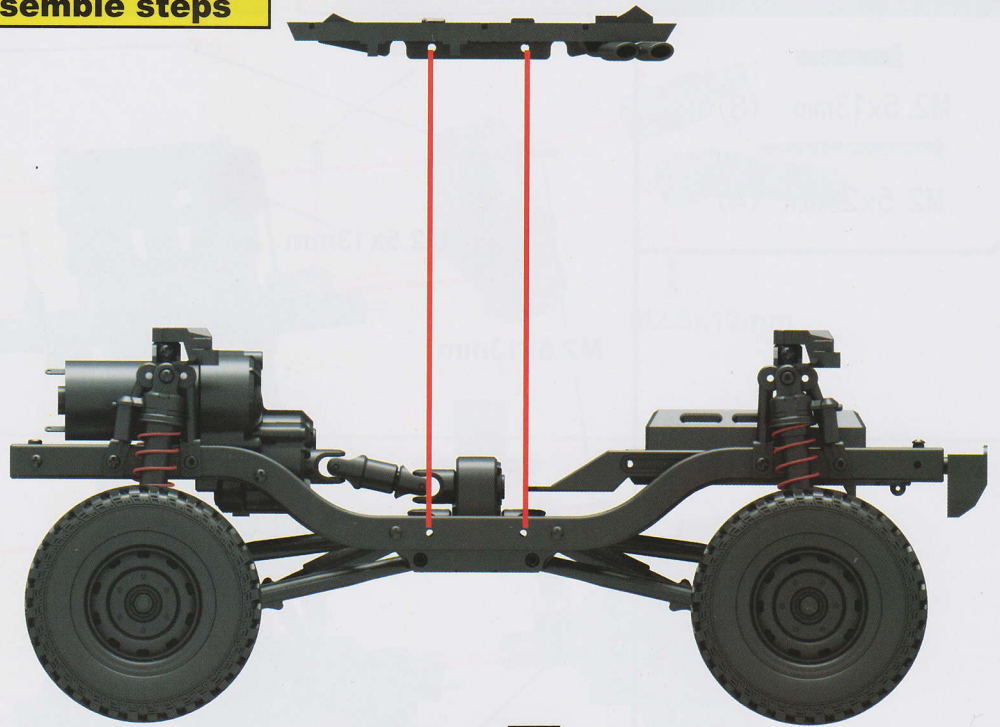

电子设备安装示意图

ELECTRONICS INSTALLATION

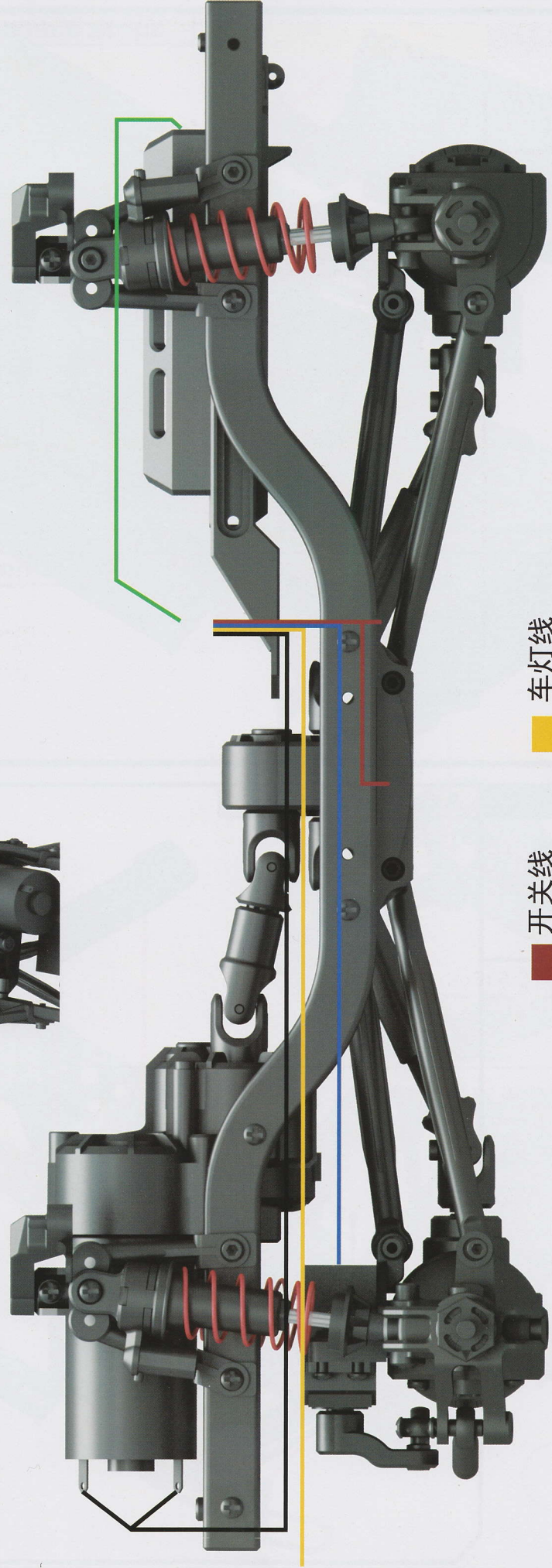

- 开关线
Switching wires
- 车灯线
Headlight wires
- 电源线
Battery wires
- 电机线
Motor wires
- 舵机线
Servo wires



prepare



车顶板
Car roof

Assemble steps



1

prepare



S4-R2



S4-L2

Assemble steps

(R)



(L)



2

prepare



2.6x6+6mm (2)
带帽螺丝
Flathead Cap Screw

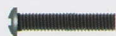

M2.5x13mm (2)

Assemble steps

2.6x6+6mm

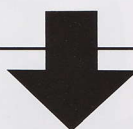

M2.5x13mm

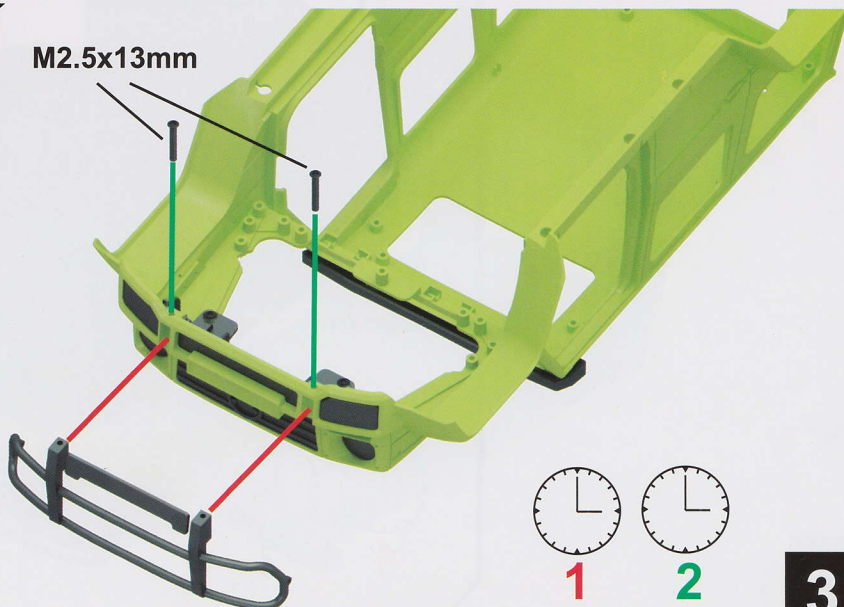

1



2

3

prepare

 2.6x6mm (4)

Assemble steps

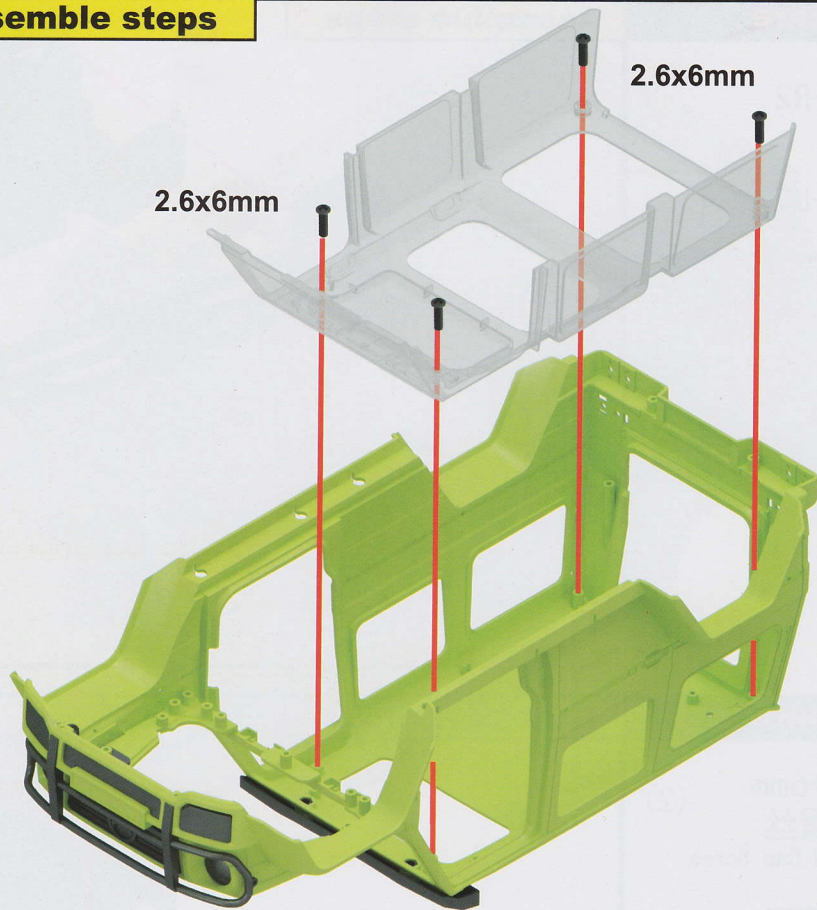

4

prepare

 2.6x6mm (3)

Assemble steps

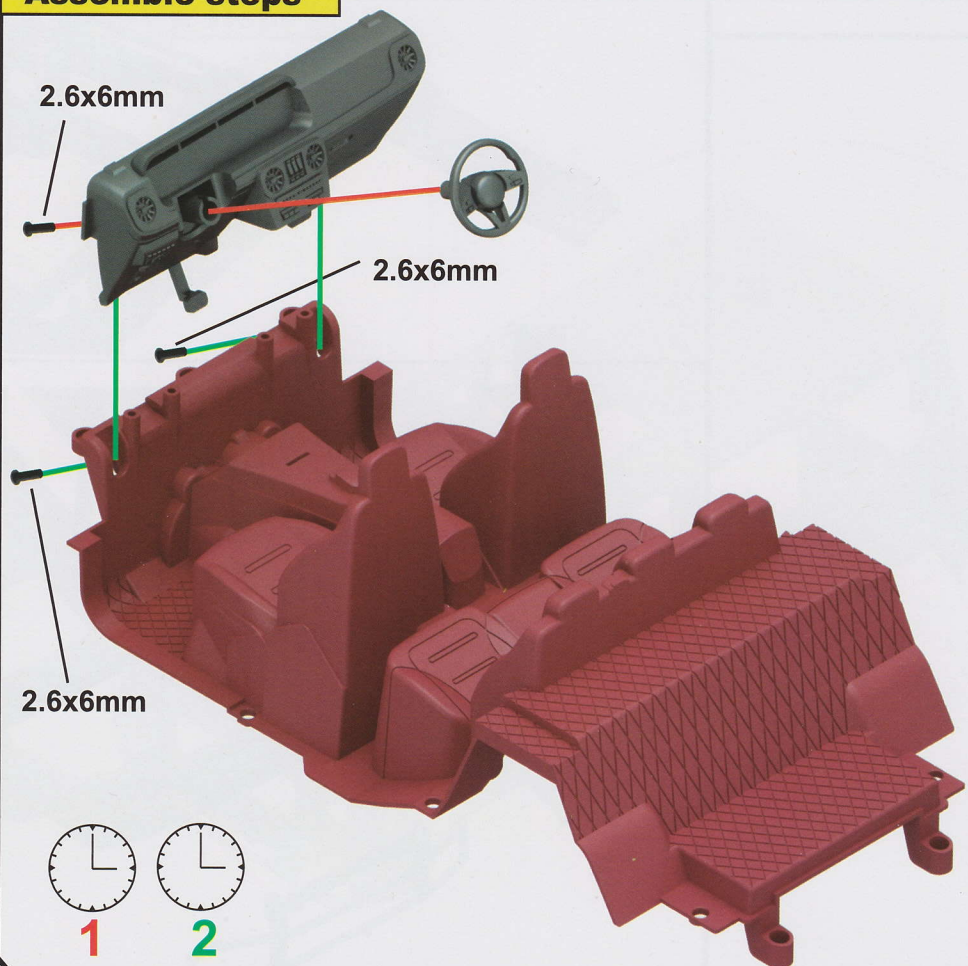

5

prepare

Assemble steps

 2.6x6mm (5)

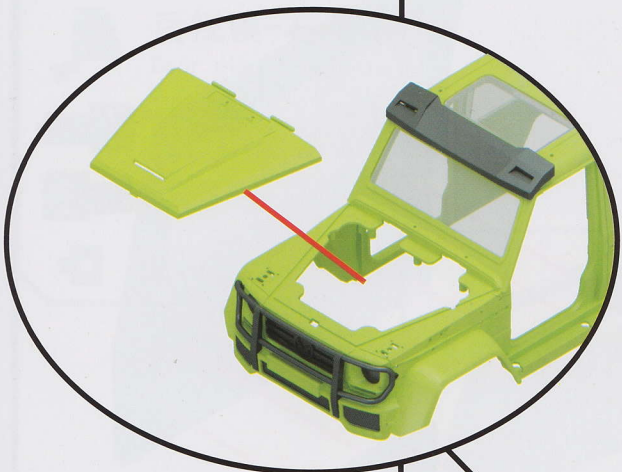
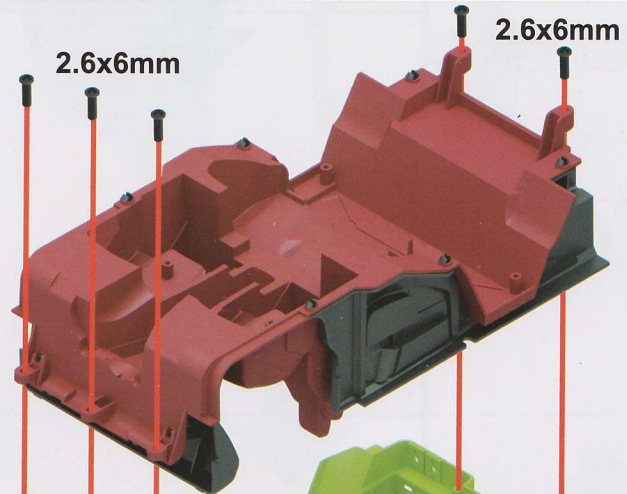
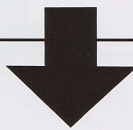
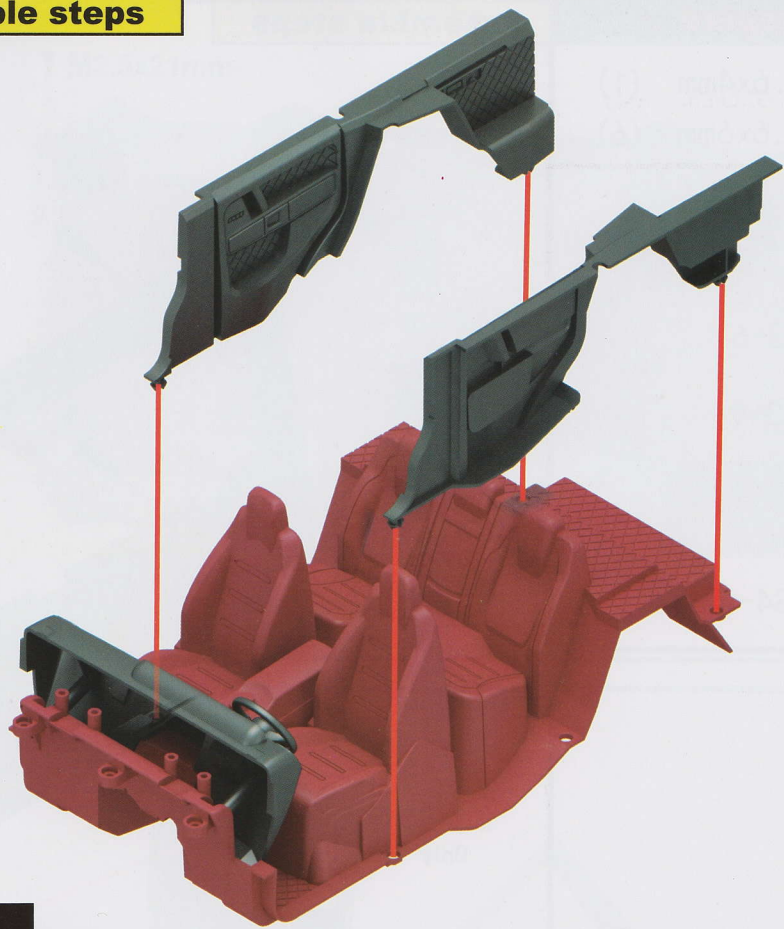

prepare

2.6x4mm (1)

2.6x6mm (6)



E2-1



E3-6



E3-9



S4-1

Assemble steps

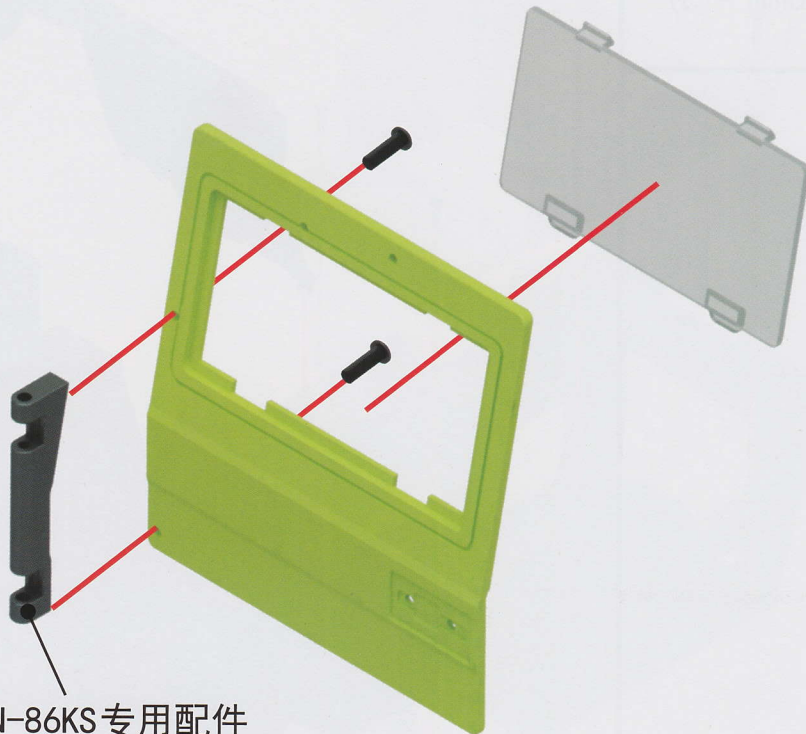

MN-86KS 专用配件
Only for MN-86KS

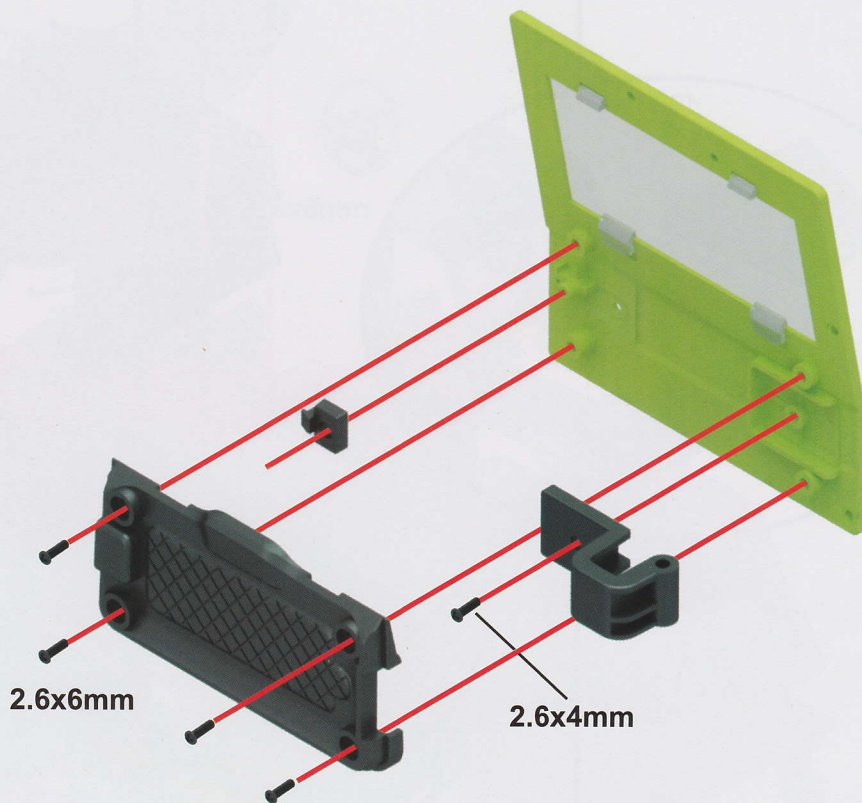
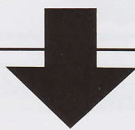

2.6x6mm

2.6x4mm

prepare



M2.5x21mm

Assemble steps

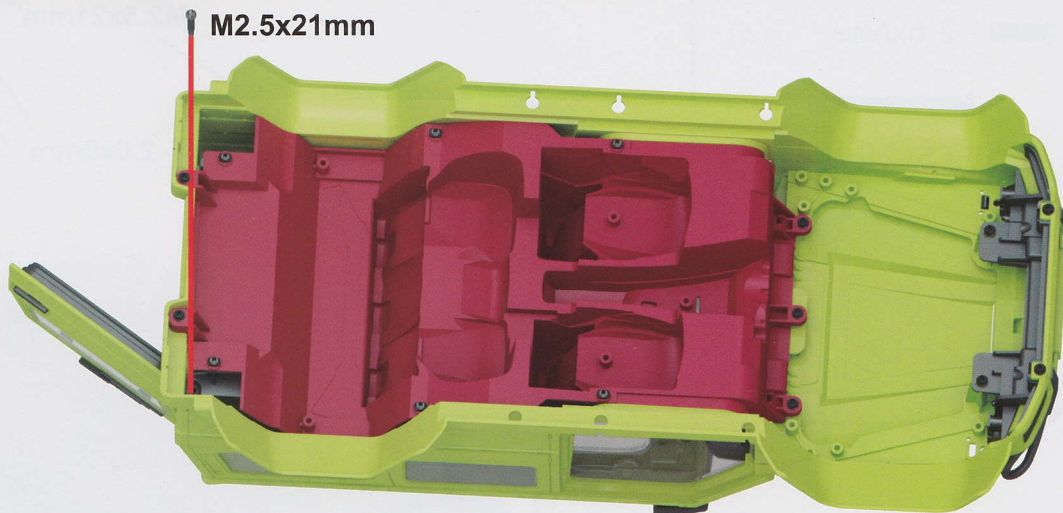

M2.5x21mm

8

prepare

2.6x4mm (4)

2.6x6mm (2)

S3-L8

S3-R8

后视镜-左
Door mirror-Left

后视镜-右
Door mirror-Right

S3-4

S3-5

S3-9

Assemble steps

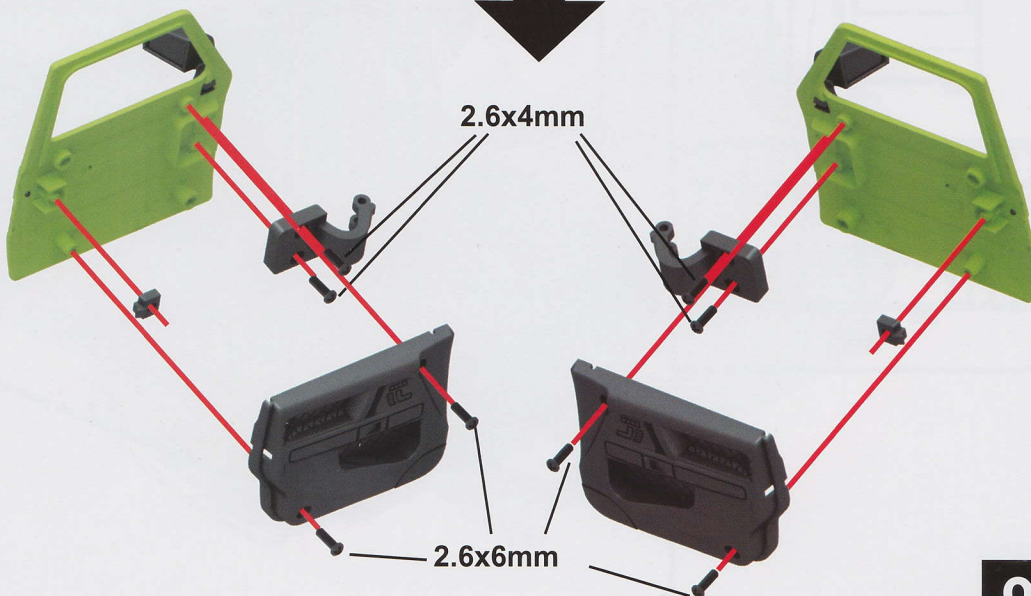
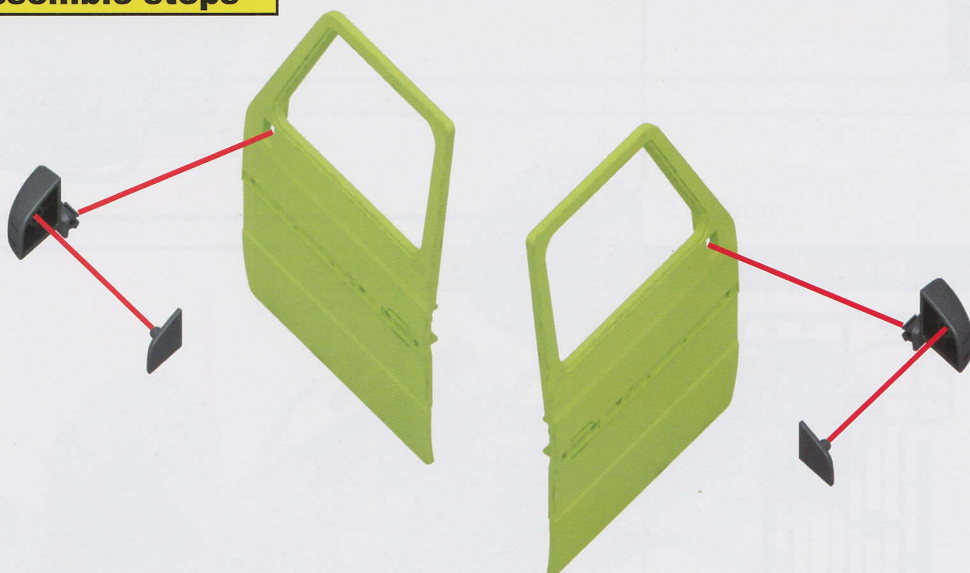

2.6x4mm

2.6x6mm

9

prepare

2.6x6mm (4)



M2.5x21mm (2)



S3-R7



S3-L7

Assemble steps

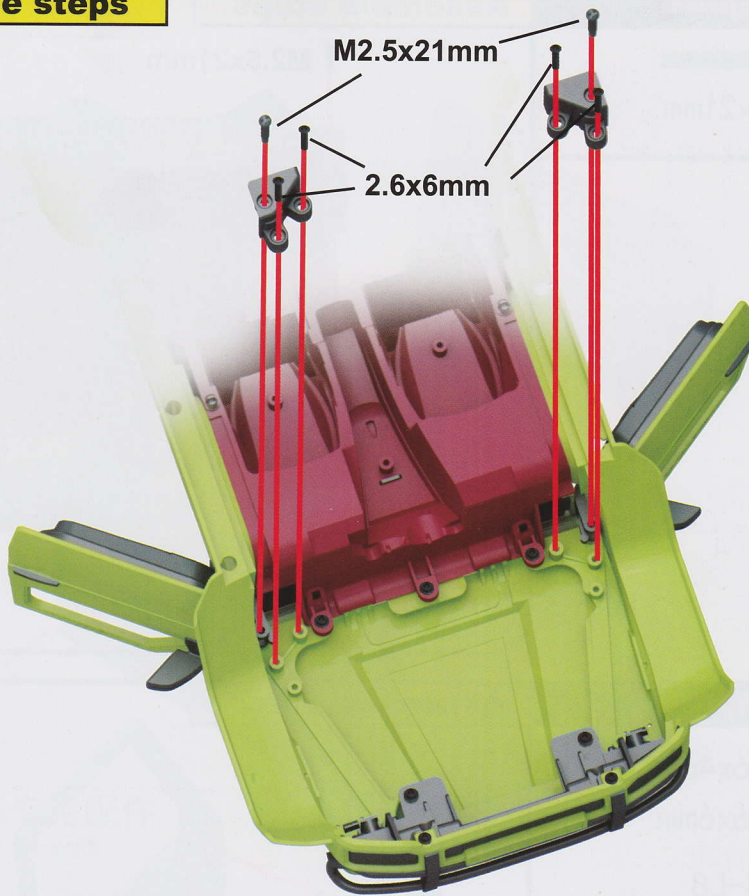

10

prepare

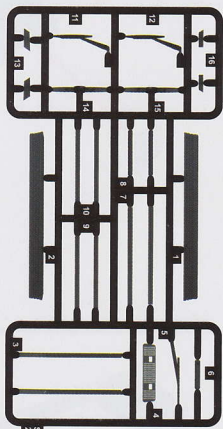

S2

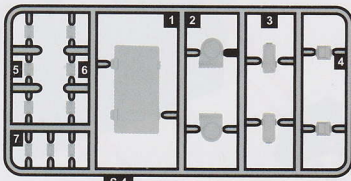

S4

Assemble steps

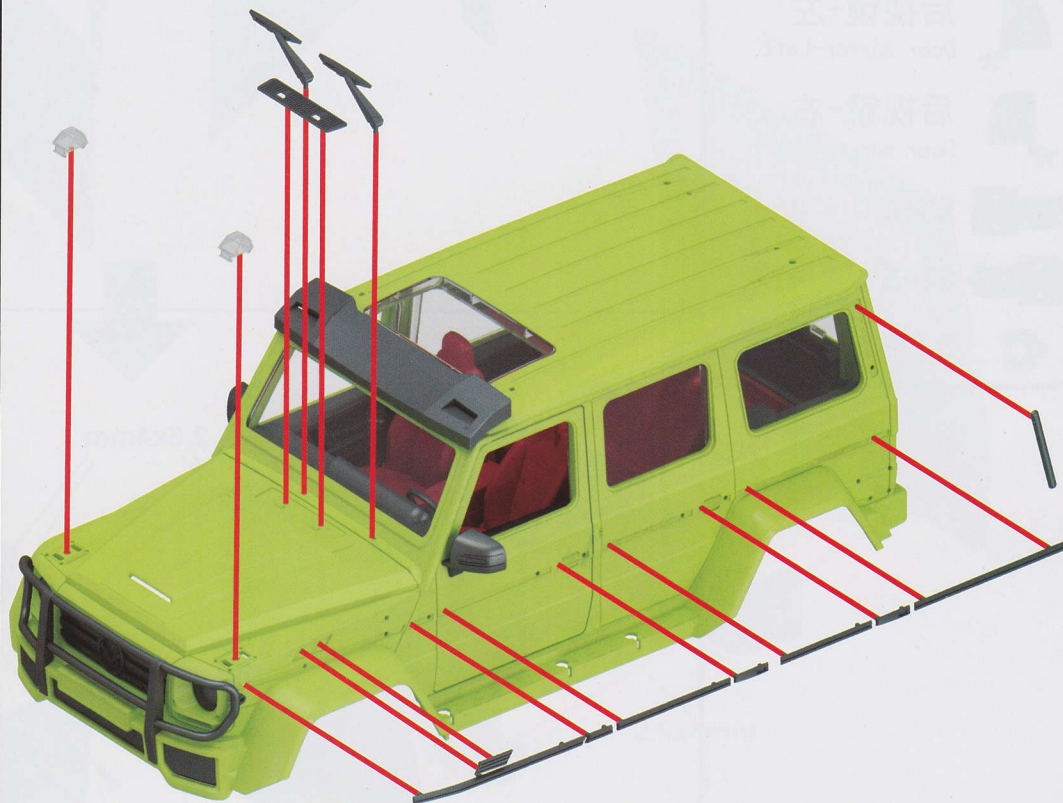

11

prepare

Assemble steps

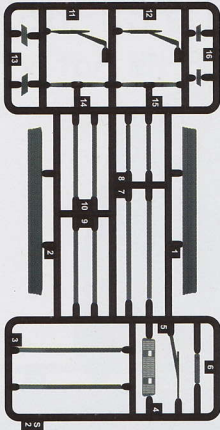

S2

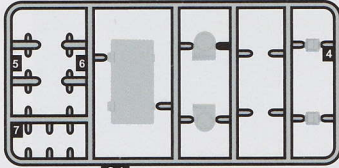

S4

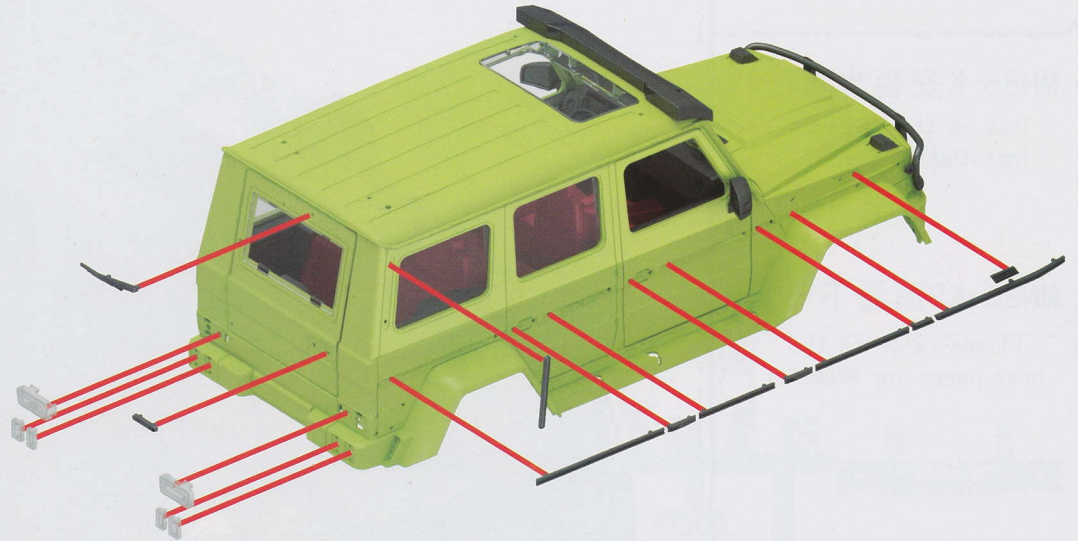

12

prepare

Assemble steps

 2.6x6mm (4)

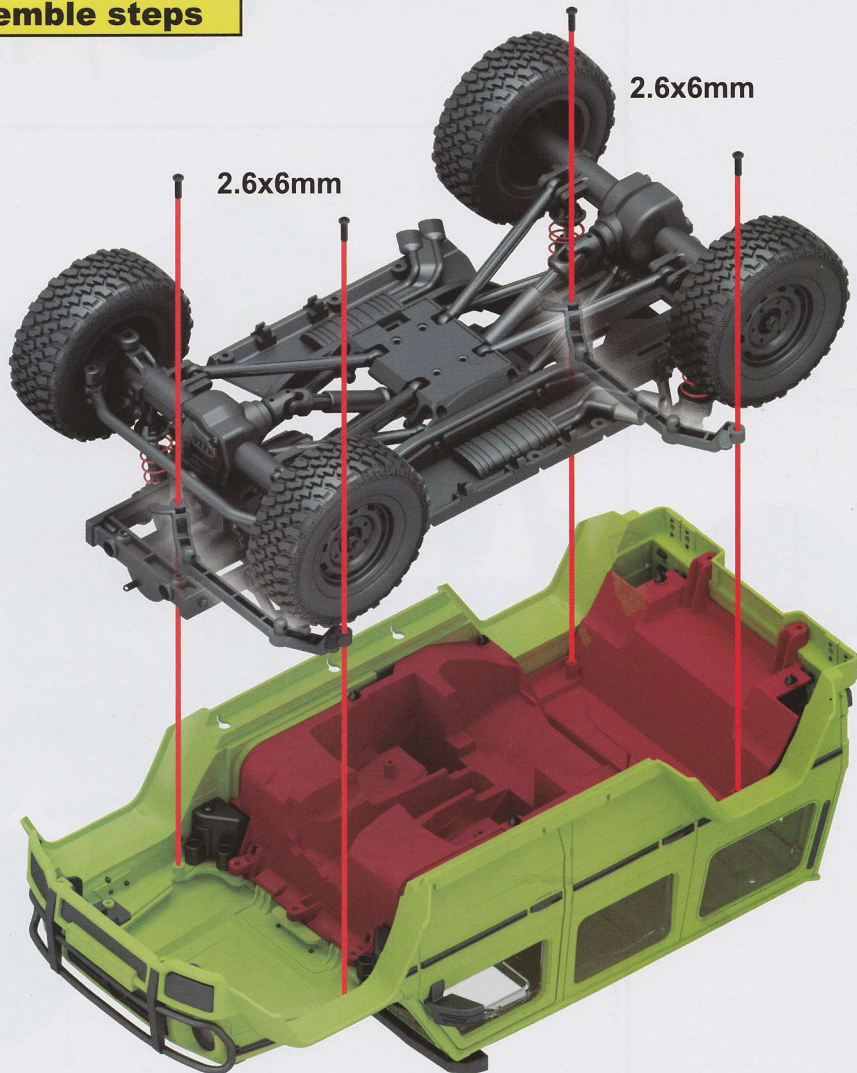

13

 2.6x6mm (6)

MN86-K安装步骤

This is the MN86-K installation steps.

MN86-KS请看下一页

Please refer to the next pages for MN86-KS

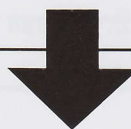
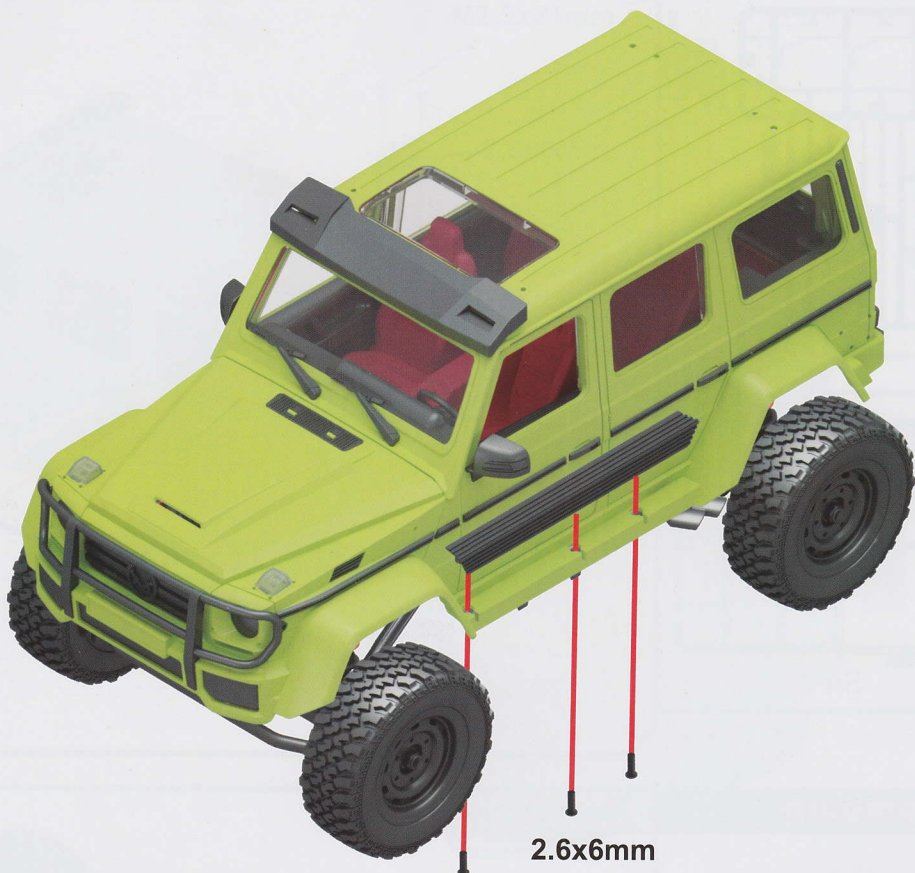

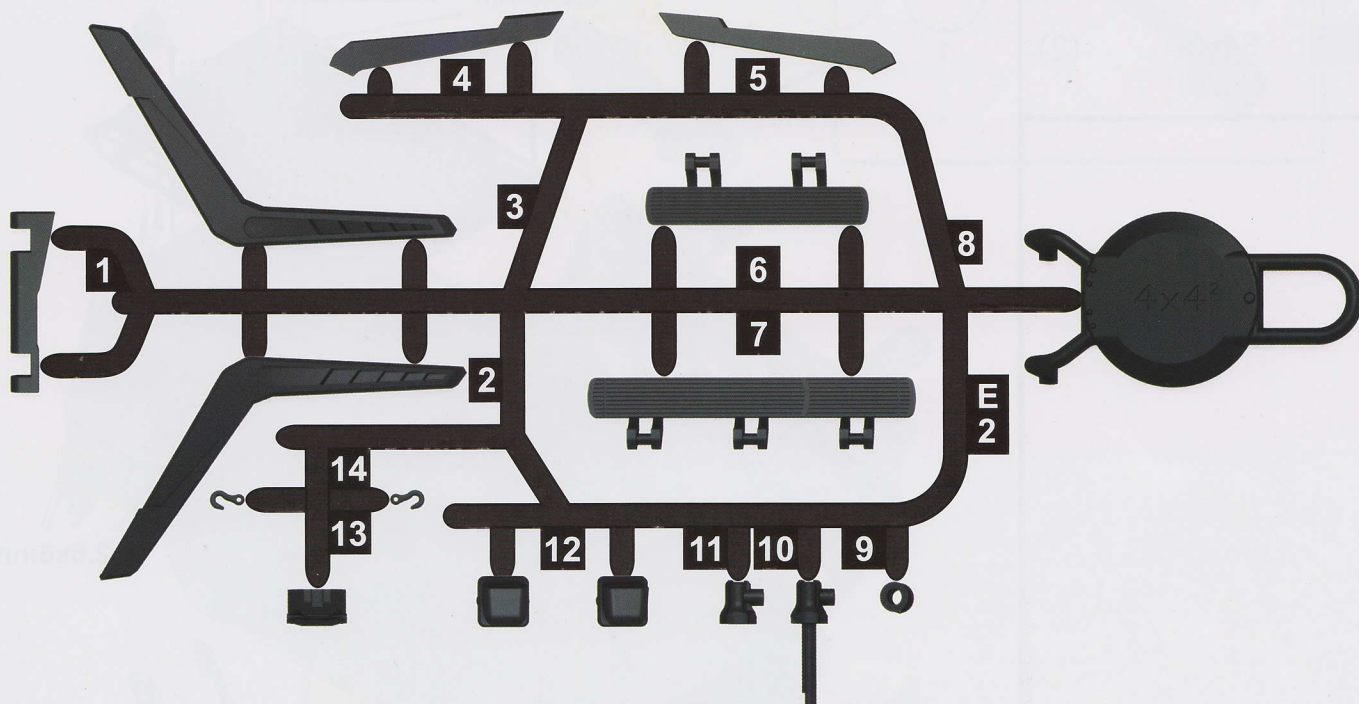
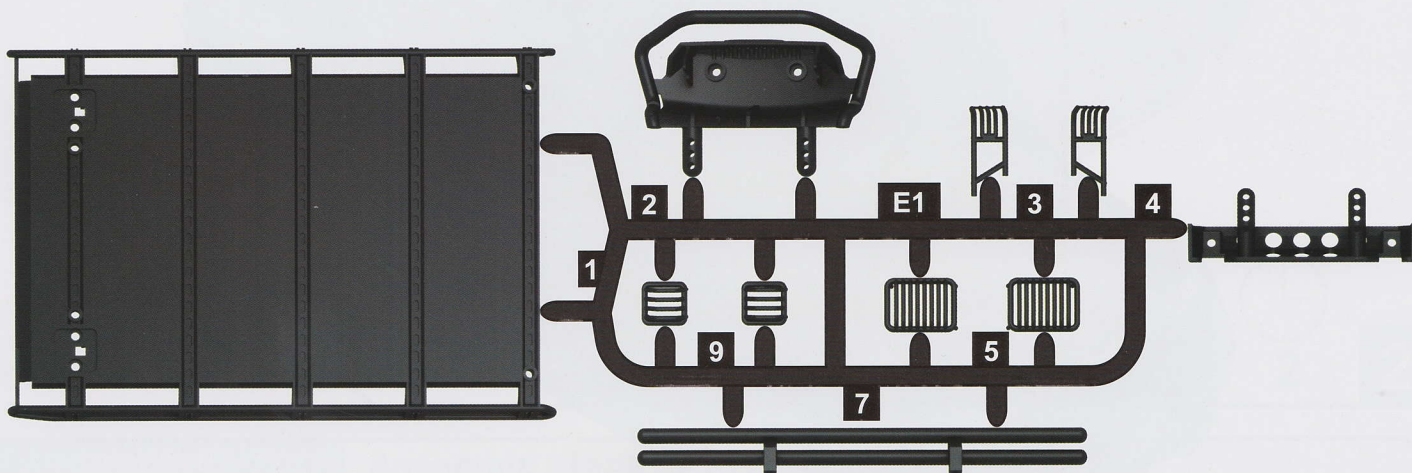

MN86-KS专用配件

Only for MN-86KS





prepare

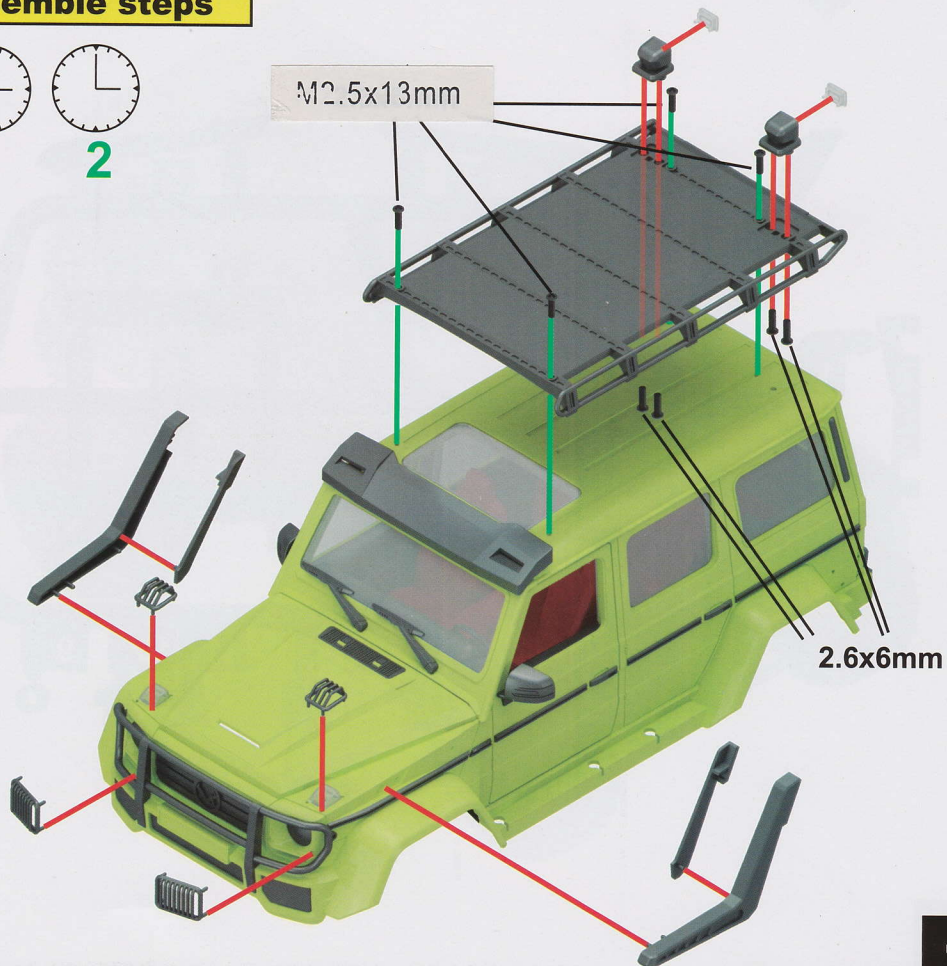
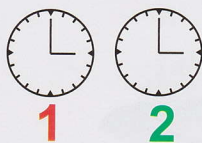

-  2.6x6mm (4)
-  S4-5 (2)

Assemble steps



1

prepare

-  2.6x6mm
-  M2.5x13mm (2)

Assemble steps

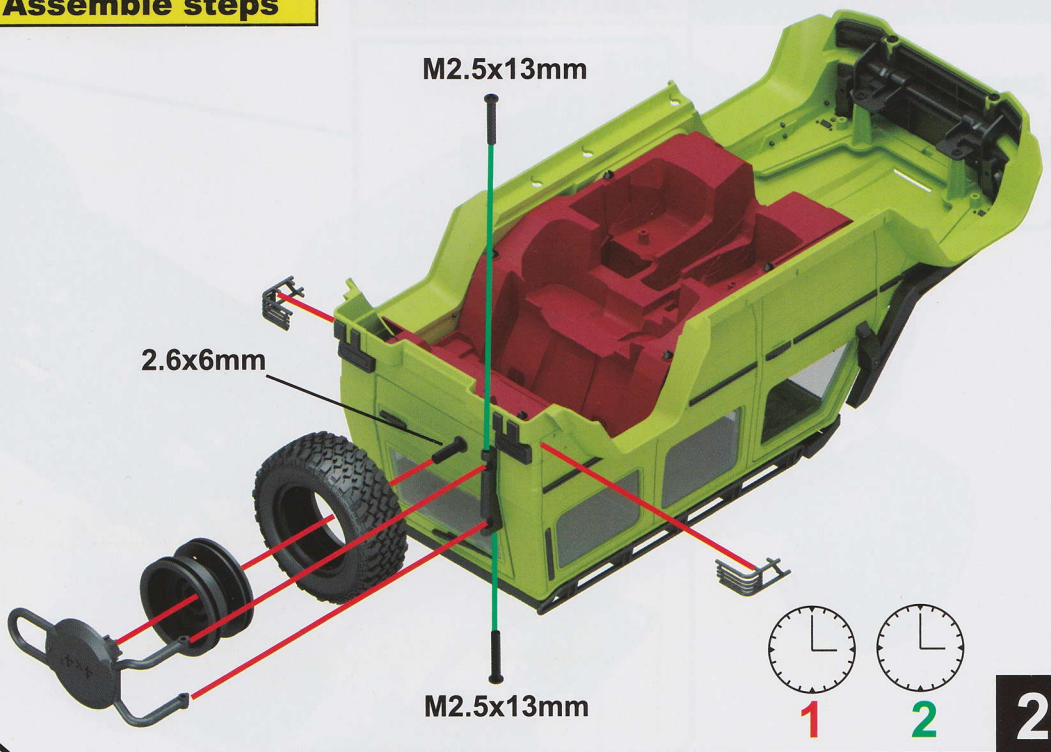

prepare

-  2.6x6mm (2)

Assemble steps

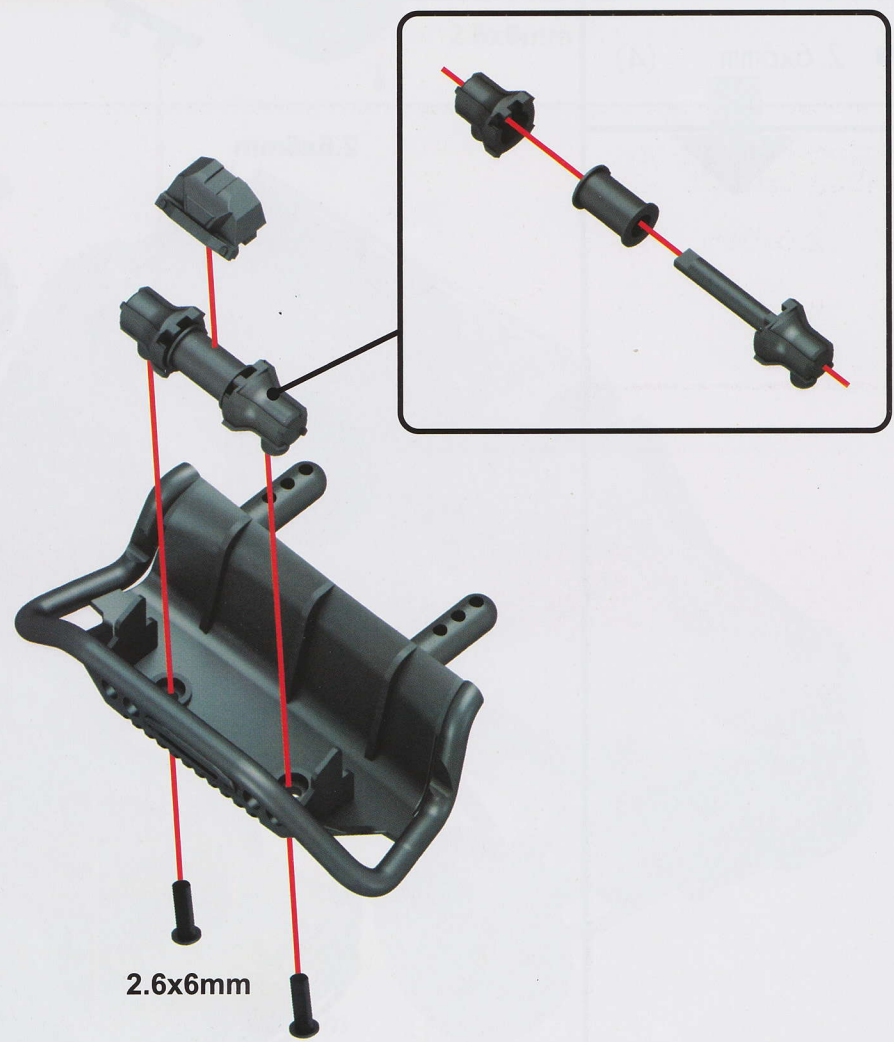

prepare

2.6x6mm (2)

M2.5x13mm (4)

Assemble steps

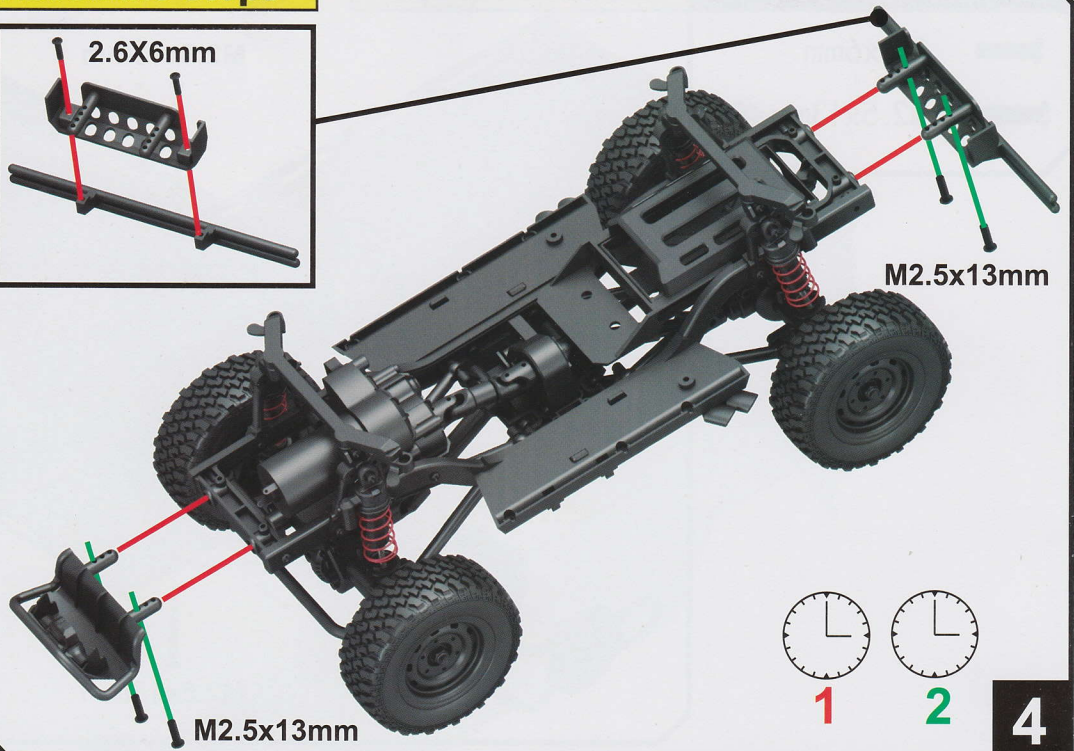
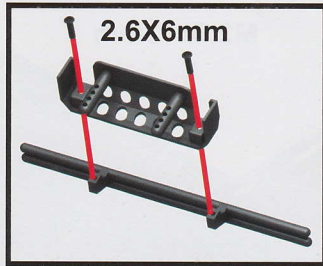

prepare

2.6x6mm (4)

Assemble steps

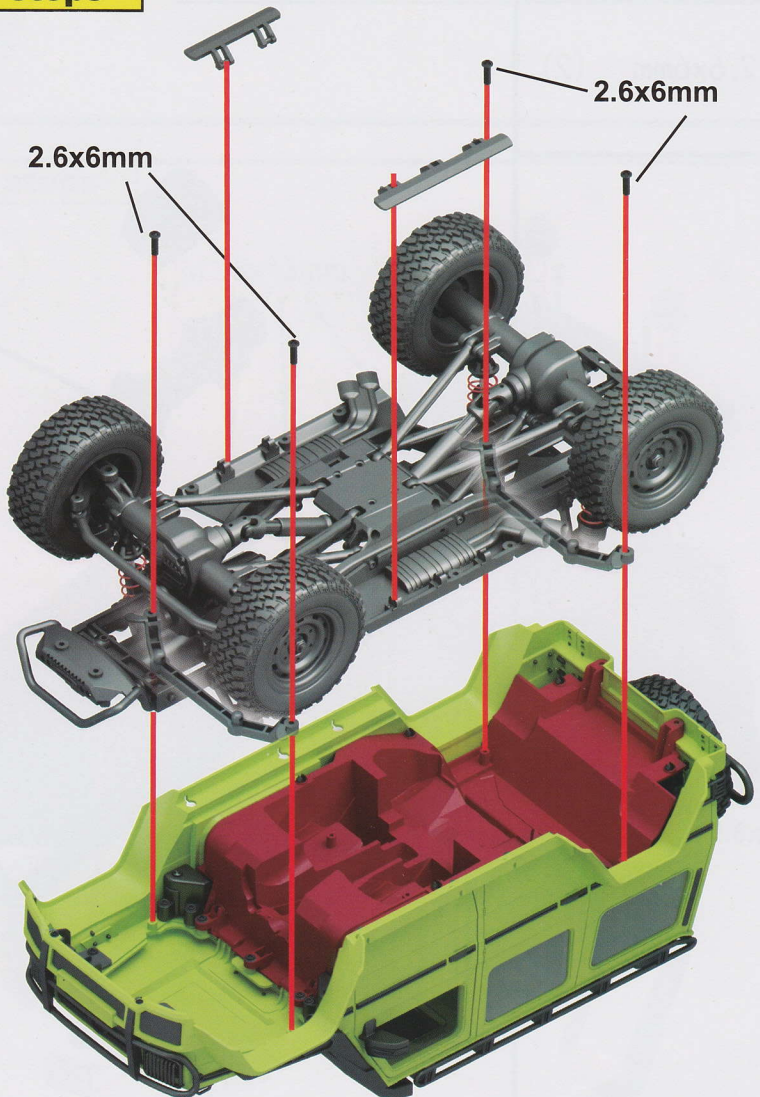

prepare

Assemble steps

 2.6x6mm (6)

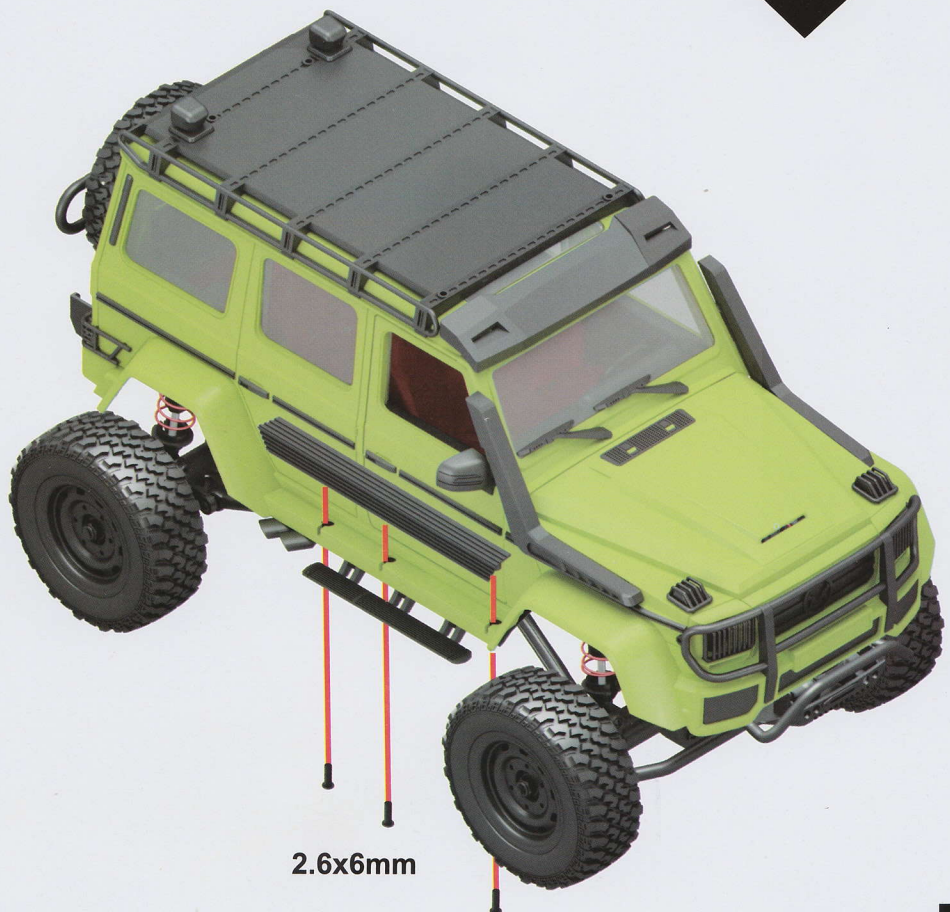
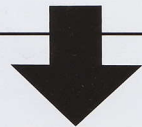
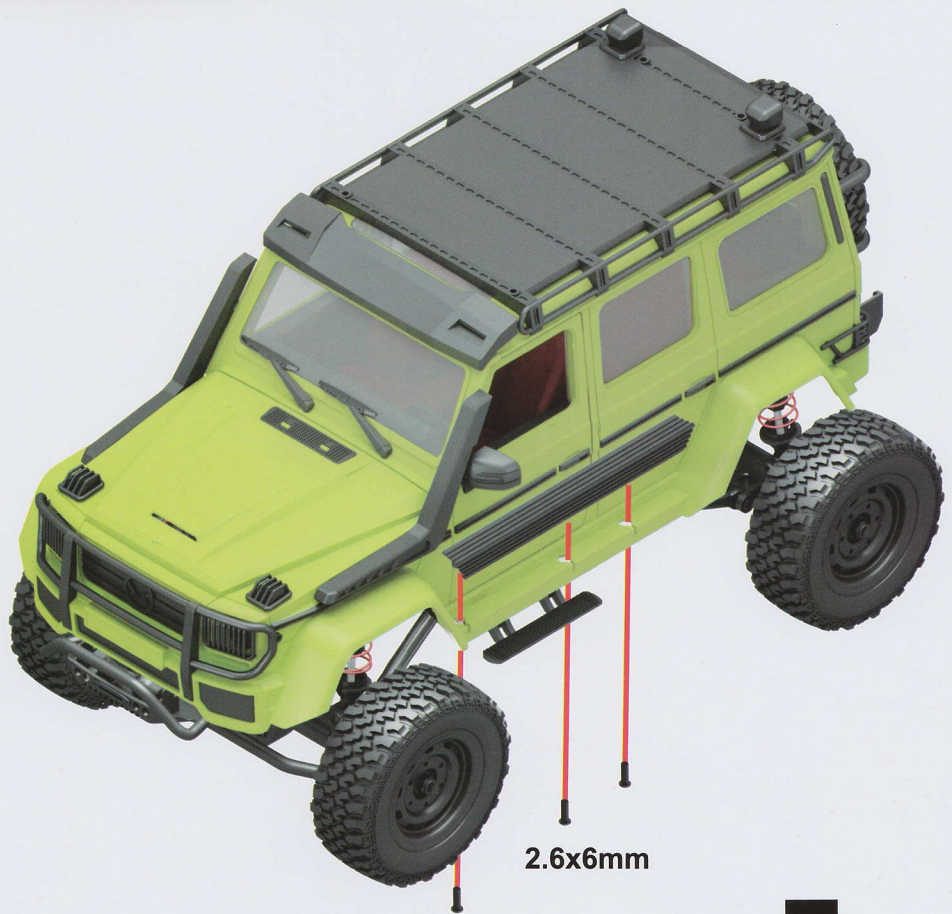



www.mn-model.com



5883270@qq.com